

■ AC Power
For *Business-Critical Continuity™*

Liebert® NXL™ UPS
Enterprise-Scale UPS Protection For Medium And Large Data Centers



Data Centers Demand Power Availability—And Much More

As critical power requirements in today's high availability data centers continue to increase, IT and facility managers are seeking greater power capacity along with superior reliability and energy efficiency. There's a new high power UPS from Emerson Network Power that meets these needs.

Liebert NXL: Advanced Global UPS Platform From The Industry Leader In Large UPS Systems

Liebert® NXL™ UPS systems from Emerson Network Power utilize the latest power protection technology to create a new level of reliability and efficiency for data center applications.

Liebert NXL UPS systems support high power applications in medium to large data centers that are facing growing power demands. The systems are designed to provide excellent dynamic performance with the ability to handle virtually any input condition—while still providing computer grade output to the critical load.

The industry leader in large UPS systems, Emerson Network Power offers the largest and most comprehensive support network, including applications engineering, project management, a witness test facility to offer proof of performance, and the industry's largest global service network.

Liebert NXL is the right choice for critical, high power applications:

- The first large UPS to be tested and UL Listed to UL 1778 fourth edition. This more harmonized internationalized standard requires testing of every specification, for a more stringent and reliable UPS.
- Handles a wide window of input distortion, including power from backup generators.
- Robust design allows operation at 100% load under a “stack-up” of conditions that would require other systems to de-rate their output or compromise system availability. Simultaneous conditions such as clogged air filters, high ambient temperature, high altitude, and low or high line conditions have been mitigated to ensure full rating at 100% operating loads.
- High inverter overload rating allows the UPS to stay on inverter delivering full regulated power, even in overload situations.
- Continuous duty rated Static Switch ensures maximum fault clearing capability in case of extreme overload or downstream short-circuits.

Liebert NXL—Stack Up Performance

100% Load
Low & High Line Conditions
40 °C / 104 °F Temperature
50% Clogged Air Filter
Fan Failure
High Altitude 1500 Meters

Liebert NXL is designed to handle all severe conditions simultaneously and still support 100% load with no need for derating.





Matching ancillary cabinets allow line-up installation with internal cabling, offering savings on installation cost and footprint. Shown: Battery Cabinet, 250kVA UPS, Maintenance Bypass Cabinet.

New Technology For A New Level Of Performance

With over four decades of the most reliable UPS systems, and the industry's most experienced engineering resources, Emerson Network Power has delivered the Liebert NXL—the latest generation of high availability, high performance UPS for critical data center equipment.

- Employs the latest generation insulated gate bipolar transistors (IGBTs) and advanced inverter logic with active harmonic control for enhanced performance under a wide range of power conditions.
- Provides high efficiency, up to 94%, but more importantly, the efficiency is optimized with a very flat efficiency curve that peaks at about 50% load where most UPS systems, especially redundant UPS systems, are operating. This results in significant savings on the energy bill.
- Digital control technology provides precise, drift-free regulation of system operation.
- Supports leading power factor loads up to 0.95 without derating, addressing the power needs of current and future generations of computers.

The Liebert NXL UPS is Ideally Suited For:

- Enterprise data centers
- Government
- Healthcare
- Finance
- Education
- Insurance
- or any other application requiring high levels of power availability and computer-grade power quality

Flexibility:

- Matching battery and maintenance bypass cabinets for easy configuration.
- Top or bottom cable entry.
- Front access for installation and service.
- Available in single-module and multi-module configurations.
- Ship-ahead I/O section can be installed before UPS installation (250-400 kVA).
- Easy, safe access for adding or changing monitoring cards without shutdown.

Higher Availability:

- Superior handling of present and future leading power factor computer loads.
- High fault current withstand capability.
- Color touch screen display improve user interface and reduce risk of human error.
- Built-in galvanic isolation offers maximized noise attenuation.
- Excellent dynamic performance.
- Liebert ActiveStar® Digital Signal Processor (DSP) controls — no potentiometers.
- Multi-module configurations provide redundancy in high-availability systems.
- Module level redundant components—fans, power supplies, communications cards.
- Up to .95 leading power factor load performance without derating.
- 100 % continuous-duty static switch.
- Generator and utility friendly with low current distortion.

Lowest Total Cost Of Ownership:

- Front access for installation and service.
- Reduced installation and service time.
- Up to 94% operating efficiency.
- Optimized part-load efficiencies.
- Improved cable access results in faster installation.
- Inter-cabinet cabling requires less wiring.
- Built-in battery cabinet breaker isolates string for ease of service.

More Ways To Achieve The Level Of Protection And Reliability You Need

Single-Module Configuration

Single-module systems provide a basic protection configuration. The critical bus is powered by a single UPS system with bypass capability. The Liebert NXL is available in 250, 300, 400 and 750 kVA single-module models.

Multi Module Configurations

Liebert NXL units can be paralleled to obtain higher total capacity or to obtain redundancy. Many facilities have added redundant UPS modules to their critical power systems, to meet the need for maximum reliability. A redundant UPS system adds fault management capability by preventing a single module or single battery failure from taking down the critical output bus. Use of redundant UPS modules also improves maintainability since one UPS module at a time can be taken off-line for service without shutting down the whole system.

Liebert NXL modules can be paralleled in 1+N as well as N+1 configurations, both configurations allows paralleling of up to 6 modules.

1+N Parallel Configuration

- Paralleling of single UPS units, offers easy scalability for increased capacity or redundancy
- Each unit has its own static switch for bypass
- Provides redundant capacity without the need for a system control cabinet

N+1 Parallel Configuration

- Paralleling of Multi Module units, without built-in static switch
- Requires System Control Cabinet with centralized static switch
- System Control Cabinet can be easily integrated into any switchgear solution
- System rated static switch with bypass breaker offers high fault clearing capability, and high availability
- Centralized monitoring allows good visibility and easy control of total system

Liebert NXL Single Module System One-Line (250-750 kVA)

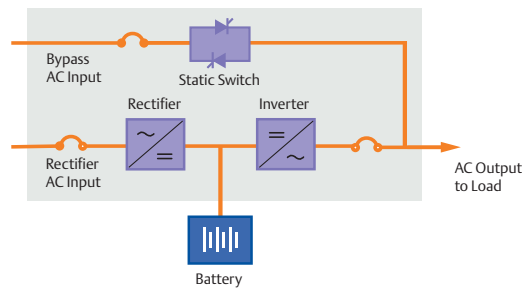

Liebert NXL 1+N Multi-Module System One-Line (250-750kVA) Distributed Static Switch

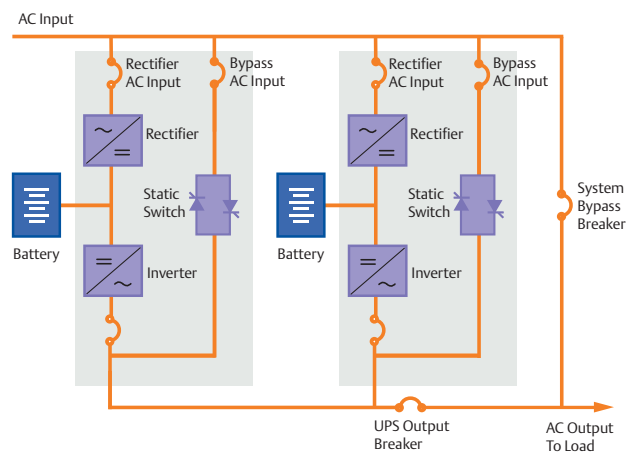

Liebert NXL N+1 Multi-Module System One-Line (750 kVA) Centralized Static Switch

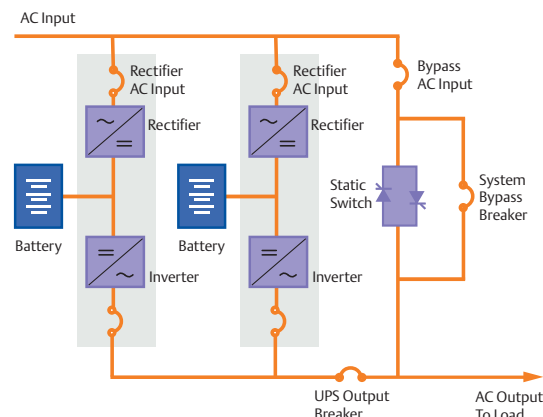

Designed For Ease Of Installation, Operation And Service

Double Doors

NEMA1 compliant even with the first set of doors open, to allow safe and easy replacement of air filters or for the addition of Liebert IntelliSlot cards without shutting down the unit.

Modular Design

All main sub-assemblies are slide out modular design to allow fast maintenance and service.

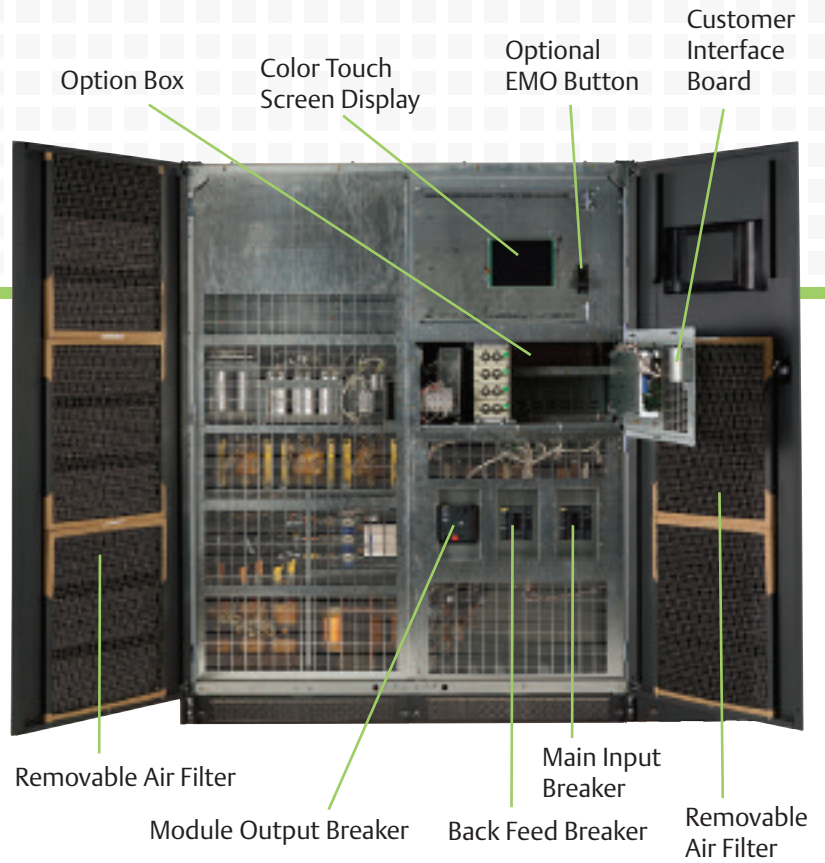

Liebert NXLI/O Cabinet

Standard included Liebert SiteScan interface

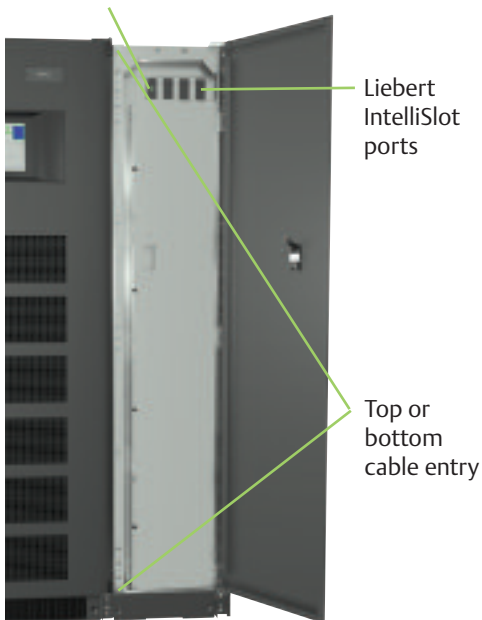

300 kVA model shown

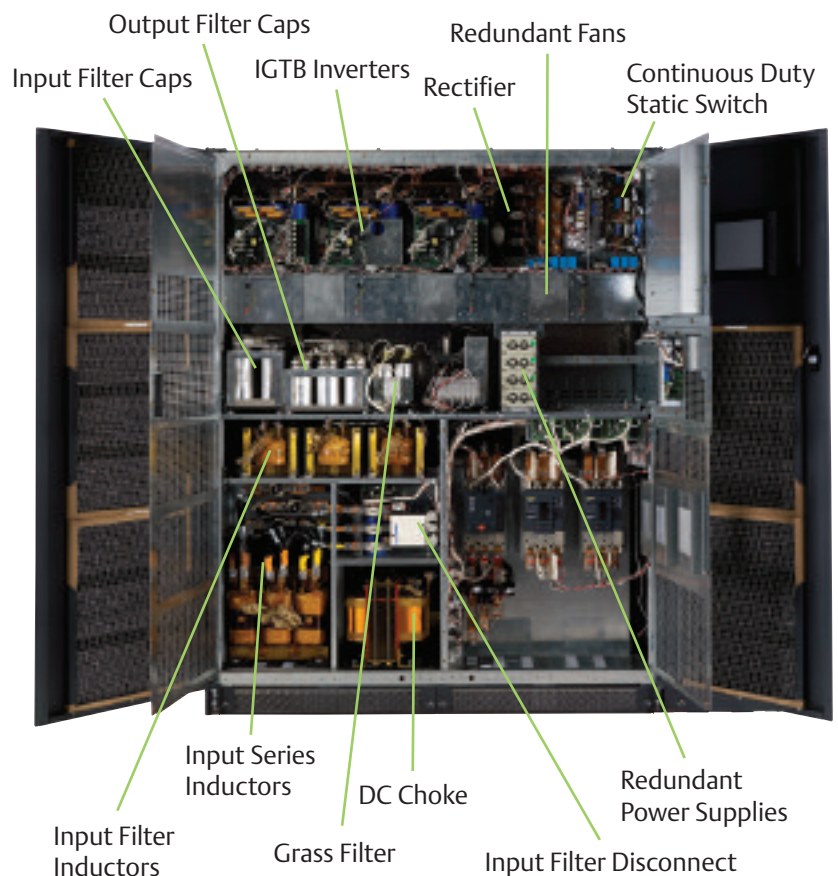

Outstanding Features Make Liebert NXL The New Benchmark In Large-Scale UPS Systems

Liebert NXL Standard Features:

- 6 pulse phase controlled SCR rectifier for 250-400kVA; 12 pulse for 750kVA
- Input filter with fuses
- Automatic input filter disconnect for input power factor control
- Copper galvanic isolation transformer
- Continuous duty static bypass with internal back feed breaker
- Redundant cooling fans
- Two step input current limit
- Two step battery charger limit
- Automatic retransfer
- DSP controls
- Back-lit color touch screen display
- Temperature compensated battery charging/battery load test
- Top and bottom cable entry
- Latest UL 1778 Rev. 4 Construction

Liebert NXL Factory Installed Options:

- Up to two programmable relay board— 8 NO/NC contacts each
- Up to two input contact isolator boards— 8 user programmable alarm inputs each
- Single input bus kit (250-400 kVA)
- Emergency Module Off (EMO)
- Display Keylock
- Breakers 65kAIC—Standard 100kAIC—Optional

Liebert NXL Field Installed Options:

- Remote Status Panel
- External Temperature Sensor—Included with matching battery cabinet
- Load Bus Sync



**Liebert NXL
(250-400 kVA)**



**Liebert NXL
(750 kVA)**

System-Matched Ancillary Products Enhance System Flexibility and Availability

A comprehensive line of ancillary products provide a matched, tested and reliable power line-up, customized for your system and site needs.



Liebert NXL Maintenance Bypass Cabinet (MBC)

- Allows UPS maintenance without load power down
- Attached and stand-alone models available
- Matched line-up design
- Top and bottom cabling
- 2 breaker configurations
- Optional Key Interlock System
- Optional Emergency Power Off (EPO)



Liebert NXL Matching Battery Cabinet

- System matched for all Liebert NXL systems
- Optional Alber BDSi integrated battery monitoring
- Breaker for safe battery service without shutdown
- Parallelable for extended runtime or redundancy



Module Battery Disconnect

- External battery circuit breaker isolates the UPS module from external battery solutions
- Easy isolation of UPS for safe service
- NEMA-1 enclosure



Liebert NXL System Control Cabinet

- For N+1 parallel units, the System Control Cabinet controls the operation of the system, and also contains the system Static Bypass Switch
- Can be integrated into the switchgear of the customers choice
- Allows control of Parallel systems with up to 6 UPS units
- Draw out design Static Bypass Switch is Continuous duty type to ensure highest availability
- On-unit advanced color touch screen display allows easy monitoring and operation of the entire parallel system

Monitoring And Control Capabilities That Keep You Informed And In Charge

Integrated Control And Monitoring Main Display Screen

Liebert NXL has a large, color touchscreen display that leads the user through logical menu sequences to view needed information.

The color, backlit, micro-processor based display is autonomous of the system control logic. The simple menu-driven system virtually eliminates the possibility for human error.

The large touch screen display can be set to show a system one-line diagram or mimic panel. It can also display advanced metering information, alarms, configuration or start-up/shutdown/transfer information.

- Quickly check operational status.
- Monitor power flow through UPS along with all meter readings.
- Menu-driven operator procedures to ensure safe operation.
- Check status reports and history files.
- Adjustment of programmable parameters (access limited by security access function).

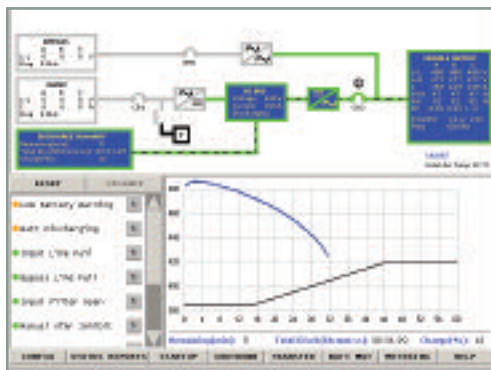

When UPS goes into battery mode, it is vital to ensure that your batteries have enough life to run the system until the generators are available. The Liebert NXL has the ability to monitor the expected run time of the batteries and provide alarms.

Battery Cycle Monitor

The Liebert NXL system firmware collects and retains information on the last 132 events that involved discharging the UPS battery. The battery discharges are categorized by discharge duration, and crucial event details are stored, providing onscreen access to information that affects battery health. Summary information on the total number of events, cumulative ampere hours and the total discharge time since a given date is also stored and available for review. All information may also be collected remotely through the Remote Service Terminal application program.

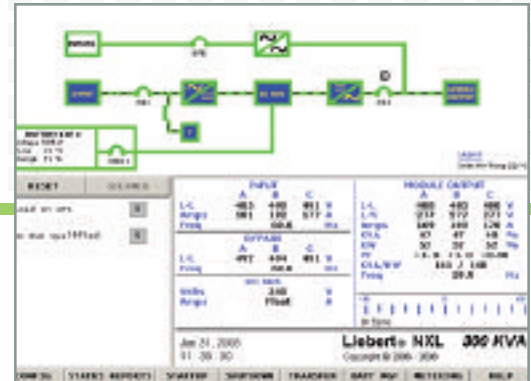

Liebert NXL Display Screen



Liebert IntelliSlot 485 Interface Card



Liebert IntelliSlot Web Card

Liebert IntelliSlot Web Card

Liebert IntelliSlot Web Card and Liebert IntelliSlot™ 485 interface card provide connection to Liebert SiteScan Web, for access to real-time control plus the tools to analyze important data about Liebert equipment. They allow the operator to access current data and interact with graphic programming logic in real-time, for full control functionality.

Battery Monitoring Options

Liebert NXL battery cabinets are available with factory integrated Alber BDSi battery monitoring. This factory installed and tested system continuously monitors and diagnoses battery parameters. The reporting function keeps data center personnel informed of battery health, and allows proactive battery replacement at the right time—not prematurely or after a cell failure. Battery monitoring may also be managed by Liebert Services, ensuring proper, timely maintenance by local, trained Customer Engineers.

Alber battery monitoring systems are also available to monitor and report on the health of wet cell batteries.

Features include:

- Windows-based software for real-time viewing, automatic data collection, data analysis, and report generating.
- Integral Ethernet network card and/or a dial-up modem as standard.
- Remote notification to third party systems via Modbus and networks.
- Scans pertinent battery parameters every 4 seconds, including total voltage, cell voltage, current and temperature.
- Automatic proactive internal DC resistance tests.
- Discharges are automatically detected and data saved for retrieval.
- Trend analysis provides the ability to analyze performance and aid in trouble shooting.



Alber BDSi Integrated Battery Monitoring for Liebert NXL Matching Battery Cabinets

Liebert SiteScan® Web Centralized Monitoring Integration

Liebert SiteScan Web centralized monitoring software offers maximum control, monitoring and visibility to Liebert NXL. All Liebert monitoring software solutions are preprogrammed with the alarms and data recording features critical to system oversight. The Liebert NXL also comes with the ability to output data directly to your network for integration with other monitoring systems. Multiple communication card options are available to deliver outputs and protocols required.



Liebert SiteScan Centralized Site Monitoring Provides Visibility and Control of All Data Center Support Equipment.



Alber BDS-256XL Monitors and Reports on the Health of Wet Cell Batteries

The Quality And Service Difference

System Witness Testing

The Liebert Adaptive Power Witness Test Center for large UPS systems is a state-of-the-art test facility designed to provide customers with pre-installation testing of the performance, interoperability, and efficiency of Liebert power modules and systems under a variety of conditions. Located in Delaware, Ohio, the 25,600 square-foot facility, including a 2,600 square-foot customer observation station, is the largest and most comprehensive in the industry.

Testing includes individual modules as well as the complete power system—including large UPS modules such as the Liebert NXL and Liebert 610 system and associated support systems—and is essential to the smooth, rapid installation and commissioning of large power systems. Customers leave the Liebert Adaptive Power Witness Test Center with documented proof and confidence that their multi-module power system will seamlessly operate in accordance with business-critical availability requirements.



Typical UPS system verification, testing and test capabilities include but are not limited to the following:

- DC functions
- Transfer functions
- Alarms and display verification
- Parallel module tests
- Module and system Internal fault testing such as component failures or power supply failures
- Module and system loading from no load up to 150% load
- Unbalanced loading
- Non-linear loading
- Battery discharge simulation
- Module and system step loading from 0 to 100%
- Short circuit tests
- Integrated tests with UPS, flywheels, switchboards, static switches, power distribution, etc
- Integrated load bus sync testing with multiple UPS systems
- Integrated powertie testing
- Integral switchgear testing
- Power quality meters
- High resistance ground
- Power monitoring
- Mimic panels
- Current and voltage harmonic analysis
- Acoustic Noise
- Key interlock systems
- PLC or relay based transfer controls
- Module and system level full load heat runs
- Infrared scanning
- Thermal scanning



Service Options

Liebert Services brings you a time-tested record of performance. Our on-site response time averages under 2 hours. For this and other reasons, nearly 100 percent of our customers recommend us.

- We have hundreds of certified engineers on staff. Each year, they undergo more than 60,000 total hours of technical training. This team is available 24x7x365 to provide application support to you.
- Our safety record is unparalleled. So is our commitment to training, in everything from low-voltage electric and OSHA lock-out/tag-out to routine safety audits and adherence to ISO standards.
- We offer a comprehensive, advanced logistics support system, with more than 7,000 unique parts stocked. We fill 97 percent of emergency part orders in less than 24 hours, and all parts are fully factory certified.
- At Liebert Services, trained professionals are available to take your call when you need us most. Our Customer Resolution Center answers hundreds of thousands of calls per year, with an average resolution time of only two and a half minutes.

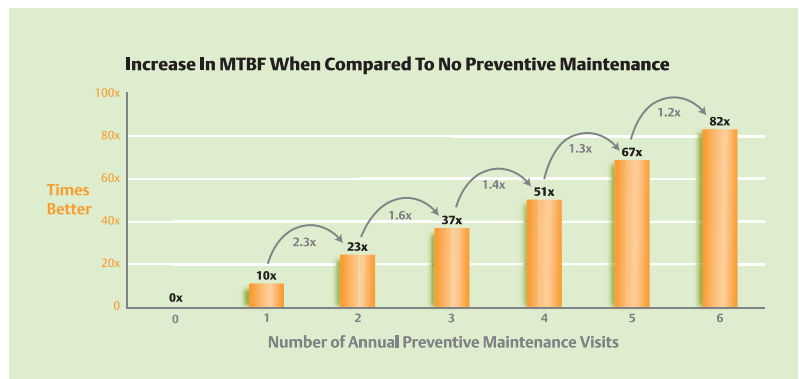

Protect Your Bottom Line

This analysis is a preliminary look at the connection between preventive maintenance and UPS system reliability for Liebert equipment. It indicates that the number of preventive maintenance visits and the service engineer's level of training have a substantial impact on system reliability. The research supports Emerson's recommendation of at least two PM visits per year, but also makes the case for more PM visits for data centers where downtime is unacceptable. Depending on the cost of downtime for a particular application, a high return on investment can be realized in many cases by increasing PM frequency.

- Regular OEM preventative maintenance increases the mean-time between failures. For instance, the MTBF for a system that receives one annual PM is 10 times greater than a system that receives zero PM.
- By contrast, a system that receives four annual PMs, as opposed to zero PMs, increases its duration between failures by 51 times.
- Data is based on MTBF analysis for three-phase UPS systems ($\geq 100\text{kVA}$) with an Emerson Network Power service agreement between 2002 and 2007.

Specifications

Liebert NXL Model Size	250	300	400	750
Input AC Parameters				
Input Voltage to Rectifier, VAC	480V 3-phase, 3-wire			
Input Voltage to Bypass, VAC	480V 3-phase, 3- or 4-wire			
Input Voltage Range, VAC	+10%, -15% (-30% battery assist)			
Input Frequency, Hz	60			
Permissible Input Frequency Range, Hz	55 to 65			
Input THDi at nominal voltage at full load, %	<10% with passive filter			<5% with passive filter
Flexi Power Walk-In, sec	1 to 30 (selectable) in 1 sec. Increments			
Battery & DC Parameters				
Battery Type	VRLA (Valve Regulated Lead Acid) or FLA (Flooded Lead Acid) or Liebert FS Flywheel			
Nominal Battery Bus, VDC	480V			
Battery Float Voltage, VDC	540V			
Recharge Time	95% capacity within 10x's discharge time			
DC Ripple Voltage in Float and Const V Ch. mode, %	<1 (RMS value) < 3.4% Vpp			
Temperature Compensated Battery Charging	Standard (with temperature probe)			
Output Parameters				
Inverter Type	IGBT PWM Control			
Output Power, kVA	250 kVA	300 kVA	400 kVA	750 kVA
Output Power, kW	225 kW	270 kW	360 kW	675 kW
Output Voltage	480VAC			
Output Voltage Regulation, %	< 1% (3-phase RMS average)			
Output Voltage Regulation (100% Unb. Load)	< 2% (3-phase RMS average)			
Output Frequency, Hz	60 Hz			
Output Frequency Regulation, %	± 0.1%			
Output THD at Nominal Voltage (Linear Load), %	<2%			
Output THD at nominal voltage Including a 100kVA Non Linear Load per EN 62040-3, %	2.5% (max)			
Efficiency	Up to 94%			Up to 92%
Transient Recovery	Within 5% peak to peak in one line cycle			
Voltage Displacement	120 deg +/- 1 deg (100% unbalanced load)			
Unbalanced loads current capacity	100% of nominal phase current			
Overload	110% for 60 minutes 125% for 10 minutes 150% for 1 minute 200% for 200ms			
Output Parameters				
Width, inches (mm)	71.8 (1823)	78.5 (1993)	78.5 (1993)	140.5 (3568) with Static Bypass, 125 (3175) without Static Bypass
Depth, inches (mm)	33.5 (850)	33.5 (850)	39.4 (1000)	39.4 (1000)
Height, inches (mm)	76.8 (1950)			
Weight, unpackaged, lb (kg) approx.	3965 (1798)	4690 (2127)	5250 (2381)	13200 (5987) with Static Bypass, 12800 (5806) without Static Bypass
Color	Black, RAL 7021			
Protection Class, UPS Enclosure	NEMA 1, IP 20 (with and without front door open)			
Standards				
Transportation	ISTA Procedure 1H			
Standards & Conformities	UL 1778 4th Edition; CSA 22.2 107.3; FCC Part 15, Class A; ANSI C62.41			
Warranty				
Standard	1 Year			

While every precaution has been taken to ensure accuracy and completeness in this literature, Liebert Corporation assumes no responsibility, and disclaims all liability for damages resulting from use of this information or for any errors or omissions.

© 2009 Liebert Corporation. All rights reserved throughout the world. Specifications subject to change without notice.

All names referred to are trademarks or registered trademarks of their respective owners.

® Liebert is a registered trademark of the Liebert Corporation.

SL-30600 (R05/09) Printed in USA

Emerson Network Power.
The global leader in enabling
Business-Critical Continuity™.

- AC Power
- Connectivity
- DC Power
- Embedded Computing
- Embedded Power
- Monitoring
- Outside Plant
- Power Switching & Controls
- Precision Cooling
- Racks & Integrated Cabinets
- Services
- Surge Protection

Business-Critical Continuity, Emerson Network Power and the Emerson Network Power logo are trademarks and service marks of Emerson Electric Co. ©2009 Emerson Electric Co.