

Sample Specification for DATA-TRACK®

Section 1- Acceptable Manufacturers

- 1.01 Manufacturer: Subject to compliance with these specifications, cable tray system shall be as manufactured by B-Line® Systems, Inc.

Section 2- Cable Tray Sections and Components

- 2.01 General: Except as otherwise indicated, provide metal cable trays, of types, classes and sizes indicated with splice hangers and all other necessary accessories. Provide cable trays with rounded edges and smooth surfaces in compliance with applicable standards, and with the following additional construction features.
- 2.02 Materials and Finish: Aluminum: Center rails and rungs shall be extruded from Aluminum Association Alloy 6063. All fabricated parts shall be made from Aluminum Association Alloy 5052 and all cast parts from Aluminum Association Alloy 319. All hardware and fasteners shall be zinc plated steel in accordance with ASTM B633.
- 2.03 Cable trays shall be constructed of a center rail 1.625" x 3.250" with minimum section properties of $S_x = 0.701 \text{ in}^3$ and $I_x = 1.174 \text{ in}^4$. Rungs shall be a single continuous square tube 0.54" x 0.54" with radiused corners and minimum section properties of $S_x = 0.019 \text{ in}^3$ and $I_x = 0.005 \text{ in}^4$. Rungs shall be mechanically connected to the center rail in at least two places, symmetrical about the center rail, with ends finished to protect installers and cables.
- 2.04 Rungs shall be spaced every [6] [9] [12] inches.
- 2.05 Straight sections shall be supplied in [10] [12] foot lengths.
- 2.06 Cable tray width shall be [6] [9] [12] [18] [24] inches.
- 2.07 Splice hangers must also be capable of acting as the support points for all thread rod.
- 2.08 Cable tray loading depth shall be [3] [4] [6] inches.
- 2.09 All splices and connectors must protect cables from the edges of the center rail and act as a barrier to prevent the center rail from transmitting hazardous gases or smoke; hardware must be installed vertically, so as not to interfere with the cables in the cable fill area.
- 2.10 Where required, expansion splices shall allow for 1" of thermal expansion and contraction.
- 2.11 When required, and to provide an area free of center rails for cable transitions, contractor shall install a universal hub fitting. The universal hub fitting must be a cast aluminum structural member, B-Line CAU Series (flat sheets of steel or aluminum are not acceptable), which can be used with cable ties and allows the center rails to be connected so they may be pivoted at connection points.

Section 3- Loading Capacities and Testing

- 3.01 Cable tray shall meet the loading requirements of NEMA 12C.
- 3.02 Upon request, manufacturer shall provide test reports in accordance with the latest revision of NEMA VE-1 or CSA C22.2 No. 126-M91.

Sample Specification for VERTI-RACK®

Section 1- Acceptable Manufacturers

- 1.01 Manufacturer: Subject to compliance with these specifications, cable tray systems shall be as manufactured by B-Line® Systems, Inc.

Section 2- Cable Tray Sections and Components

- 2.01 General: Except as otherwise indicated, provide metal cable trays, of types, classes and sizes indicated with splice hangers and all other necessary accessories. Provide cable trays with rounded edges and smooth surfaces in compliance with applicable standards, and with the following additional construction features.
- 2.02 Materials and Finish: Aluminum: Center rails and rungs shall be extruded from Aluminum Association Alloy 6063. All fabricated parts shall be made from Aluminum Association Alloy 5052 and all cast parts from Aluminum Association Alloy 319. All hardware and fasteners shall be zinc plated steel in accordance with ASTM B633.
- 2.03 Cable trays shall be constructed of a center rail 1.625" x 3.900" with minimum section properties of $S_x = 0.558 \text{ in}^3$ and $I_x = 1.272 \text{ in}^4$. Rungs shall be a single continuous rectangular tube 0.54" x 0.31" with radiused corners and minimum section properties of $S_x = 0.007 \text{ in}^3$ and $I_x = 0.001 \text{ in}^4$. Rungs shall be mechanically connected to square trunks 0.71" x 0.71", symmetrical about the trunk, with ends finished to protect installers and cables. Trunks shall be mechanically connected to the center rail.
- 2.04 Rungs shall be spaced every [6] [9] [12] inches.
- 2.05 Straight sections shall be supplied in [10] [12] foot lengths.
- 2.06 Cable tray width shall be [3] [6] [9] [12] inches.
- 2.07 Splice hangers must also be capable of acting as the support points for all thread rod.
- 2.08 Cable tray loading depth shall be 2 inches.
- 2.09 Cable tray shall have [2] [3] [4] [5] [6] tiers.
- 2.10 All splices and connectors must protect cables from the edges of the center rail and act as a barrier to prevent the center rail from transmitting hazardous gases or smoke; hardware must be installed vertically, so as not to interfere with the cables in the cable fill area.
- 2.11 Where required, expansion splices shall allow for 1" of thermal expansion and contraction.
- 2.12 When required, cable tray system shall be expandable after installation, up to two additional tiers.

Section 3- Loading Capacities and Testing

- 3.01 Cable tray shall meet the loading requirements of NEMA 12C.
- 3.02 Upon request, manufacturer shall provide test reports in accordance with the latest revision of NEMA VE-1 or CSA C22.2 No. 126-M91.

Sample Specification for HALF-RACK®

Section 1- Acceptable Manufacturers

- 1.01 Manufacturer: Subject to compliance with these specifications, cable tray systems shall be as manufactured by B-Line® Systems, Inc.

Section 2- Cable Tray Sections and Components

- 2.01 General: Except as otherwise indicated, provide metal cable trays, of types, classes and sizes indicated with splice hangers and all other necessary accessories. Provide cable tray with rounded edges and smooth surfaces in compliance with applicable standards, and with the following additional construction features.
- 2.02 Materials and Finish: Aluminum: Center rails and rungs shall be extruded from Aluminum Association Alloy 6063. All fabricated parts shall be made from Aluminum Association Alloy 5052 and all cast parts from Aluminum Association Alloy 319. All hardware and fasteners shall be zinc plated steel in accordance with ASTM B633.
- 2.03 Cable trays shall be constructed of a center rail 1.625" x 3.250" with minimum section properties of $S_x = 0.701 \text{ in}^3$ and $I_x = 1.174 \text{ in}^4$. Rungs shall be a single continuous square tube 0.54" x 0.54" with radiused corners and minimum section properties of $S_x = 0.019 \text{ in}^3$ and $I_x = 0.005 \text{ in}^4$. Rungs shall be mechanically connected to the center rail in at least two places, with ends finished to protect installers and cables.
- 2.04 Rungs shall be spaced every [6] [9] [12] inches.
- 2.05 Straight sections shall be supplied in [10] [12] foot lengths.
- 2.06 Cable tray width shall be [3] [6] [9] [12] inches.
- 2.07 Splice hangers must also be capable of acting as the support points for all thread rod.
- 2.08 Cable tray loading depth shall be [3] [4] [6] inches.
- 2.09 All splices and connectors must protect cables from the edges of the center rail and act as a barrier to prevent the center rail from transmitting hazardous gases or smoke; hardware must be installed vertically, so as not to interfere with the cables in the cable fill area.
- 2.10 Cable tray shall be capable of being installed flush against a flat surface without the use of spacers or brackets.
- 2.11 Where required, expansion splices shall allow for 1" of thermal expansion and contraction.

Section 3- Loading Capacities and Testing

- 3.01 Upon request, manufacturer shall provide test reports in accordance with the latest revision of NEMA VE-1 / CSA C22.2 No. 126.1-98.

Sample Specification MULTI-TIER HALF-RACK®

Section 1- Acceptable Manufacturers

- 1.01 Manufacturer: Subject to compliance with these specifications, cable tray systems shall be as manufactured by B-Line® Systems, Inc.

Section 2- Cable Tray Sections and Components

- 2.01 General: Except as otherwise indicated, provide metal cable trays, of types, classes and sizes indicated with splice hangers and all other necessary accessories. Provide cable tray with rounded edges and smooth surfaces in compliance with applicable standards, and with the following additional construction features.
- 2.02 Materials and Finish: Aluminum: Center rails and rungs shall be extruded from Aluminum Association Alloy 6063. All fabricated parts shall be made from Aluminum Association Alloy 5052 and all cast parts from Aluminum Association Alloy 319. All hardware and fasteners shall be zinc plated steel in accordance with ASTM B633.
- 2.03 Cable trays shall be constructed of a center rail 1.625" x 3.900" with minimum section properties of $S_x = 0.558 \text{ in}^3$ and $I_x = 1.272 \text{ in}^4$. Rungs shall be a single continuous square tube 0.54" x 0.54" with radiused corners and minimum section properties of $S_x = 0.019 \text{ in}^3$ and $I_x = 0.005 \text{ in}^4$. Rungs shall be mechanically connected to square trunks 0.71" x 0.71", with ends finished to protect installers and cables. Trunks shall be mechanically connected to the center rail.
- 2.04 Rungs shall be spaced every [6] [9] [12] inches.
- 2.05 Straight sections shall be supplied in [10] [12] foot lengths.
- 2.06 Cable tray width shall be [3] [6] [9] [12] inches.
- 2.07 Splice hangers must also be capable of acting as the support points for all thread rod.
- 2.08 Cable tray loading depth shall be [3] [4] inches.
- 2.09 Cable tray shall have [2] [3] [4] tiers.
- 2.10 All splices and connectors must protect cables from the edges of the center rail and act as a barrier to prevent the center rail from transmitting hazardous gases or smoke; hardware must be installed vertically, so as not to interfere with the cables in the cable fill area.
- 2.11 Cable tray shall be capable of being installed flush against a flat surface without the use of spacers or brackets.
- 2.12 Where required, expansion splices shall allow for 1" of thermal expansion and contraction.
- 2.13 When required, cable tray system shall be expandable after installation, up to two additional tiers.

Section 3- Loading Capacities and Testing

- 3.01 Upon request, manufacturer shall provide test reports in accordance with the latest revision of NEMA VE-1 / CSA C22.2 No. 126.1-98.

Installation Suggestions

Common Items Required:

- 10 ft (3.0m) or 12 ft (3.7m) Straight Sections with Standard Splice Hangers. (pgs. 14-21)
- Horizontal Adjustable Splices (pg. 26)
- Vertical Adjustable Splices (pg. 30)
- Horizontal Elbow & Tee Coupling (pgs. 27-28)
- Universal Hub Fittings with Pivot Connectors (pg. 31)
- Clevis Hangers (pgs. 34-35)
- 1/2" ATR & Hex Nuts (pg. 42)
- Beam Clamps (pg. 41)
- Anchors (pg. 43)
- Two 3/4" Combination Wrenches

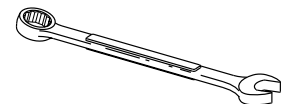
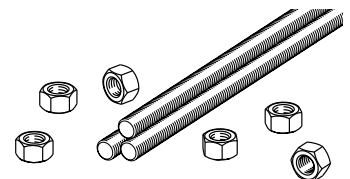
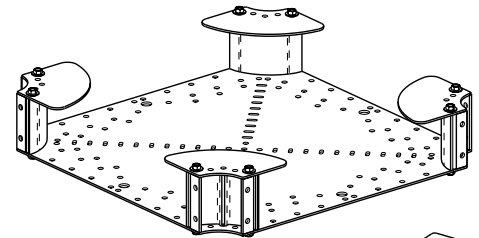
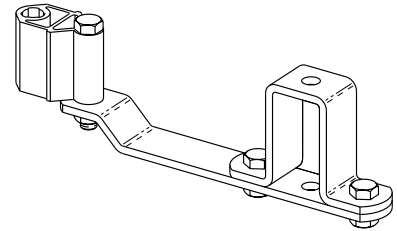
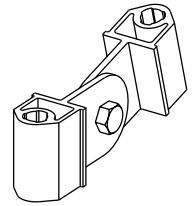
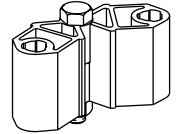
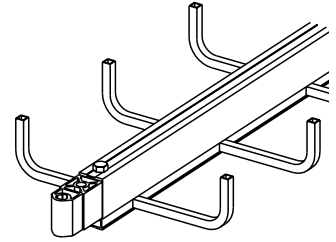

Installation Suggestions

Guidelines for Common Items:

- When field cutting is required, use drill fixture (pg. 53) to cut ends square and locate new splice holes, or drill one $\frac{9}{16}$ " (14mm) hole $\frac{7}{8}$ " (22mm) on center from end of the tray through center rail.

IMPORTANT: Tube end must be cut square when field cutting.

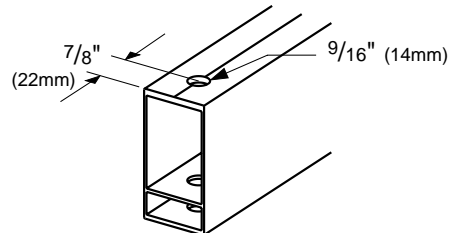

- When hanging ATR, leave slightly loose until after tray is installed to ease alignment with splice hanger holes.
- When attaching the tray system to the ATR, extend the ATR approximately 1" past the hex nut to allow for the use of B655 rod couplings (pg. 42) for future expansion.

- **To address unbalanced loading.**

When tray stabilization is required for non-uniform loading, use brackets with ATR as shown: (pg. 39)

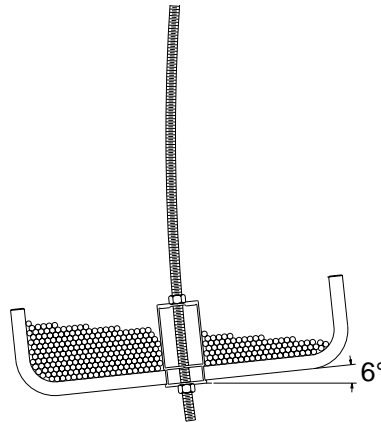

- Page A-3 - unbalanced loading study.
- Refer to page 37 for auxiliary support

- CENT-R-RAIL® tray was designed to be interactive with B-Line's strut systems, allowing multiple options for miscellaneous supports. Refer to B-Line's Strut Systems catalog and seismic brochure for a complete listing of items available. A few examples are shown below:

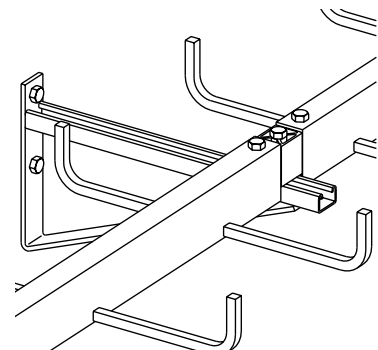
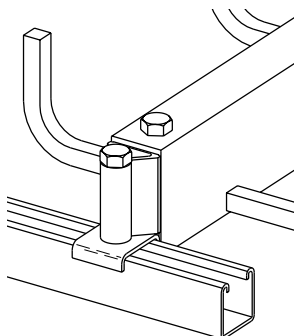
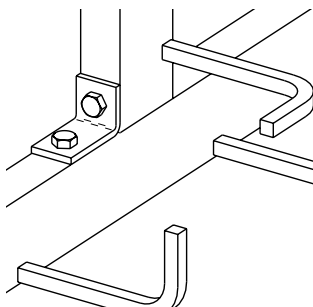

Installation Suggestions

Guidelines for Common Items:

• When installing straight sections:

- Hang 1/2" ATR on 10 ft or 12 ft centers (depending on tray lengths) with one hex nut threaded approximately 4 inches onto ATR.
- Attach splice hanger and tray onto ATR through center hole of splice hanger.
- Install one hex nut on ATR under tray and thread up to set elevation of tray.
- Tighten upper hex nut against top of splice hanger.
- For wall attachment options see Seismic Restraints Cent-R-Rail® Supplement (SRSCR1).

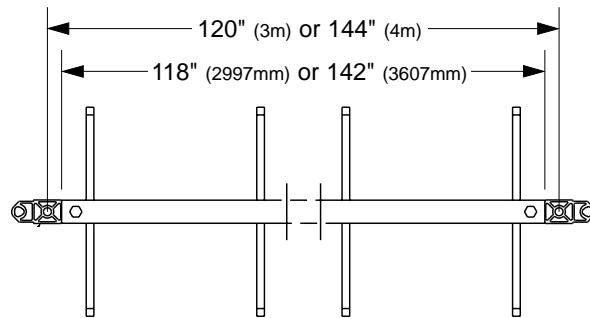

• When using Qwik-Bolt® Splice Hangers:

- Insert splice into ends of tray with non-threaded side toward bolt head.
- Insert bolts and tighten securely.

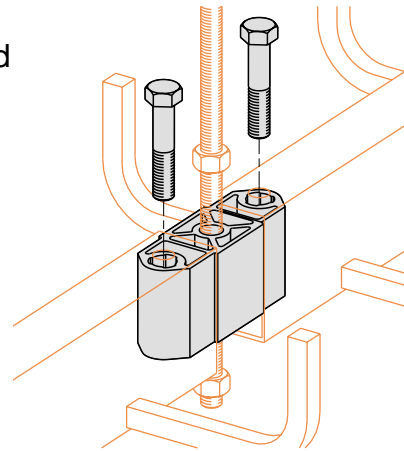

• Allow for future expansion

- When possible, extend ATR 1" past bottom hex nut to provide for later expansion by using an ATR coupling (pg. 42).

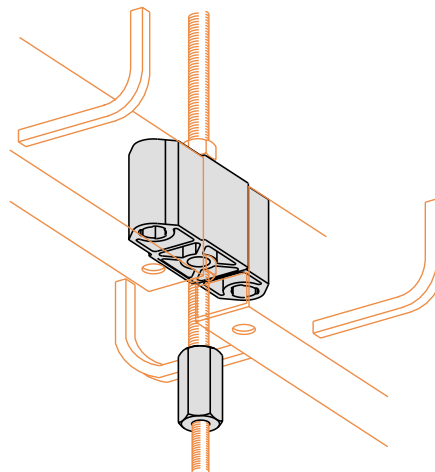

Installation Suggestions

Guidelines for Common Items:

• When using Horizontal Adjustable Splices:

- Install with ATR through center hole, adjust splice to required angle and tighten ATR nuts.
(May also install with the included 3" bolt and nut, and support tray using a clevis hanger within 2 ft of splice.)
- For optional outside bend cable support, horizontal bend rung support (pg. 26).

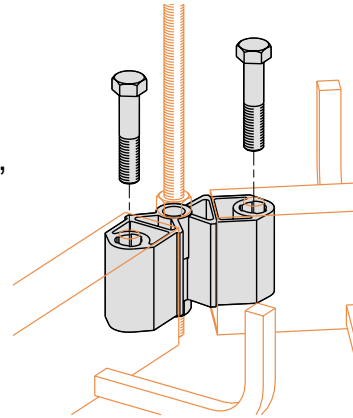

• For connecting two mid-run straight pieces:

- Use Horizontal Adjustable Splices to join two straight sections at mid-run, where short of space for connection.

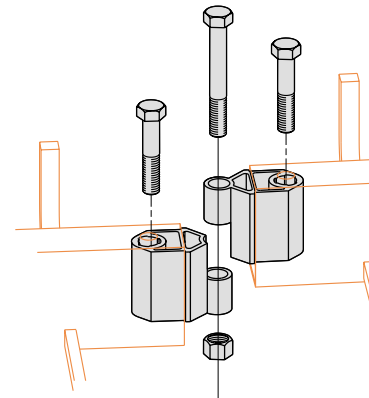

• When using Vertical Adjustable Splices:

- Attach splice to trays and install a clevis hanger within 2 ft of splice to support tray.
(May also install using ATR as support by first removing captive nut.)
- Tighten pivot bolt & nut.

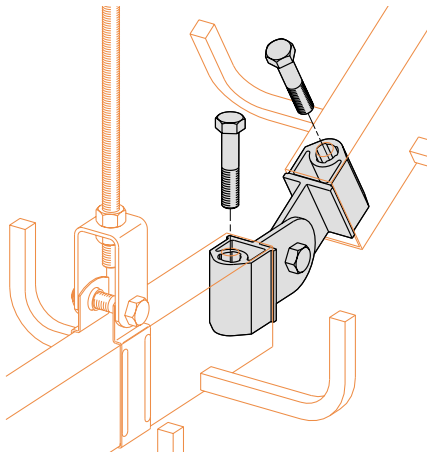

• Removing the captive nut

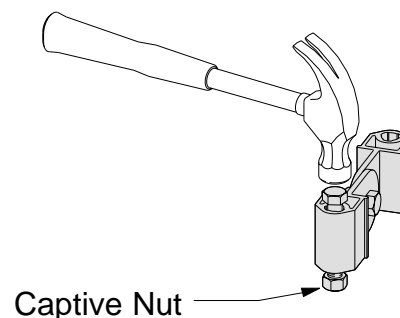

Installation Suggestions

Guidelines for Common Items:

- **When using Expansion Splice Hangers:**

- Both splices adjacent to expansion splice hangers must be installed 120" or 144" (depending on the tray length) on centers from expansion splice to allow full expansion and contraction.
- Grounding jumper must be installed with expansion splice.

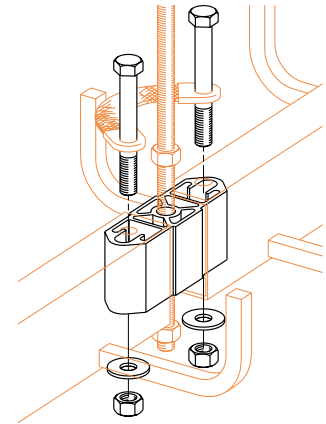
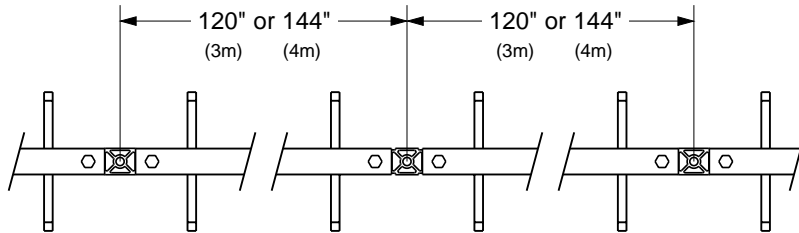

Half-Rack® and Multi-Tier Half-Rack® Support Locations

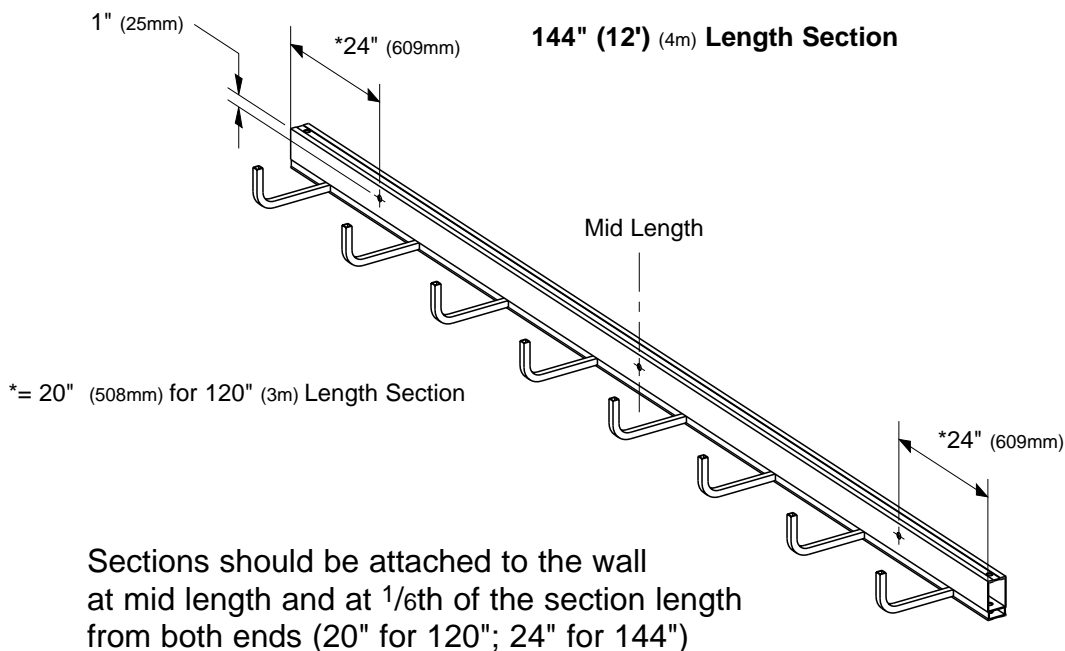

- **When wall-mounting tray:**

- Attach tray and splice to wall by bolting through center rail to wall. (May also be installed using other methods, such as brackets.)

Installation Suggestions

Guidelines for Common Items:

Half-Rack® Mounting Details:

• Drill Through Method: In Concrete Slab

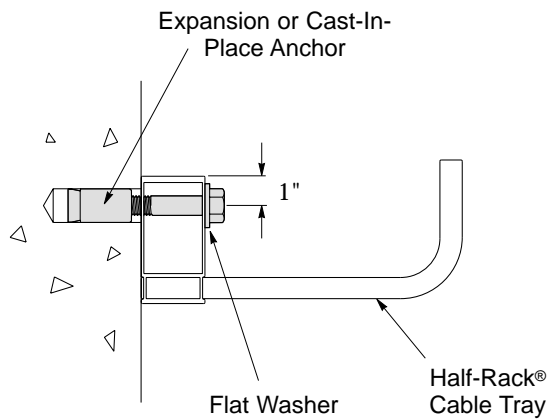

• B594 Clevis U-Bracket: In Concrete Slab

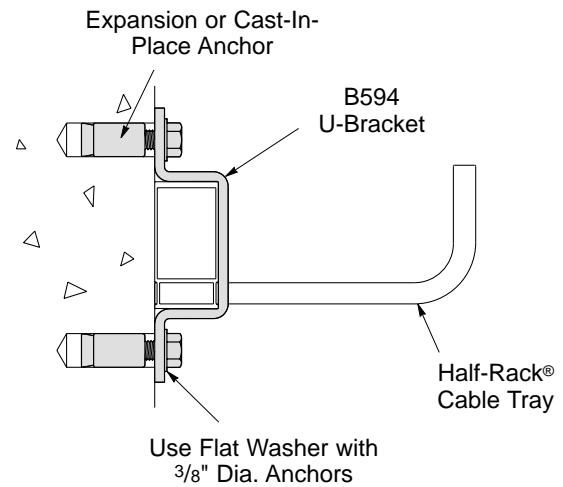

• CZNH-WH Wall Hanger: In Hollow CMU Wall

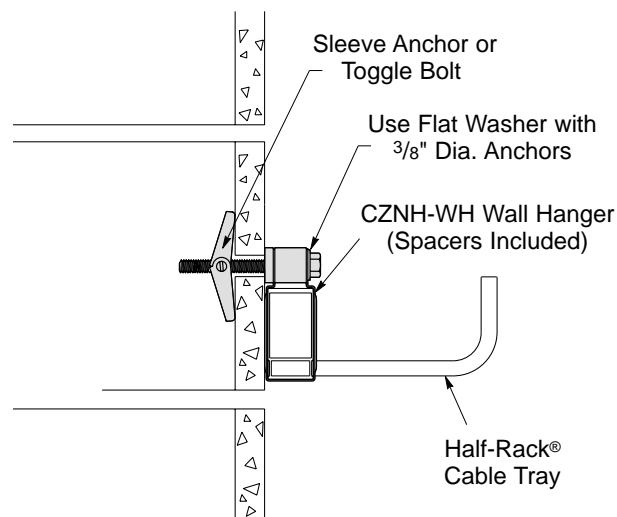

• CPB-U10 U-Bracket: In Drywall & Metal Stud Wall

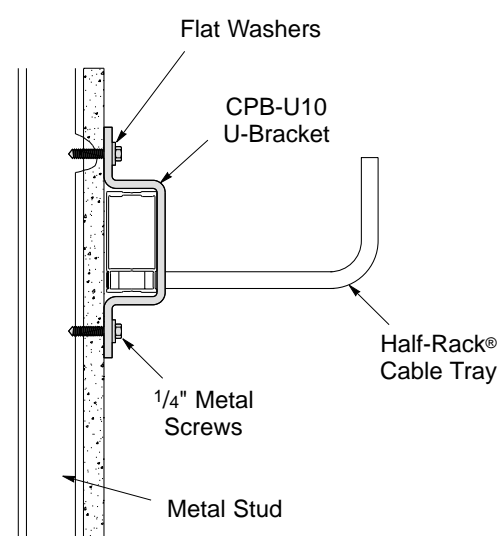

Note: These mounting details serve as a vertical support, and can serve as seismic bracing. See the Cent-R-Rail Seismic Restraints brochure (SRSCR1) for details.

Installation Suggestions

Guidelines for Common Items:

Multi-Tier Half-Rack® Mounting Details:

- **CZNH-WM Wall Hanger:
In Concrete Slab**

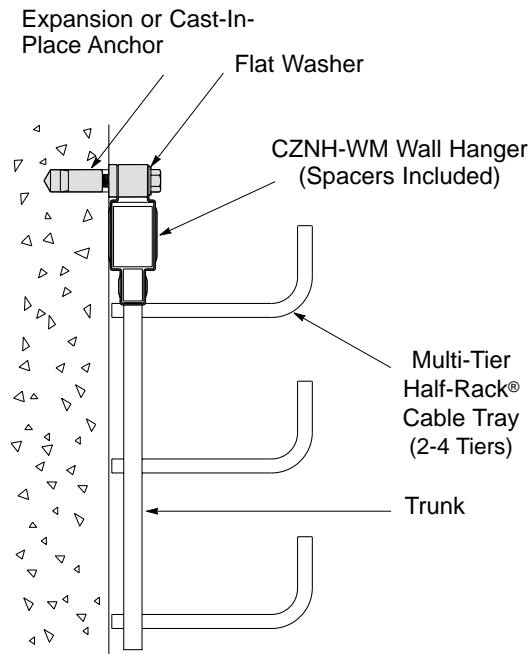

- **CZNH-WM Wall Hanger:
In Hollow CMU Wall**

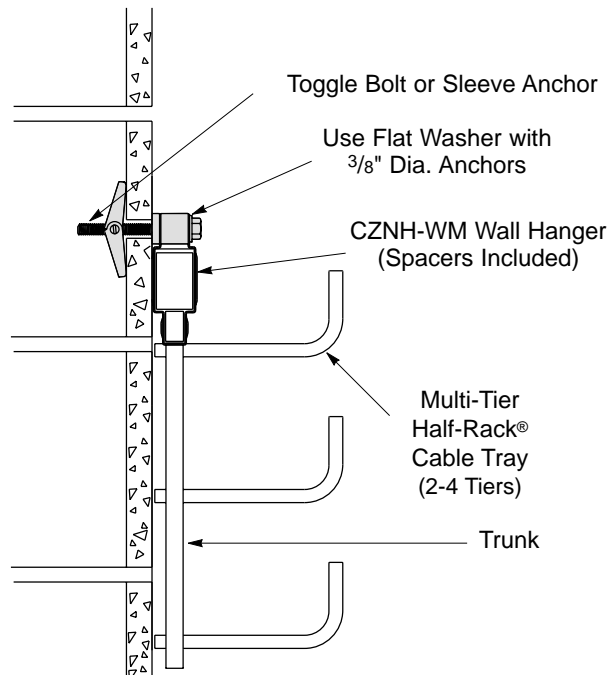

- **B594 Clevis U-Bracket:
In Wood Stud Wall**

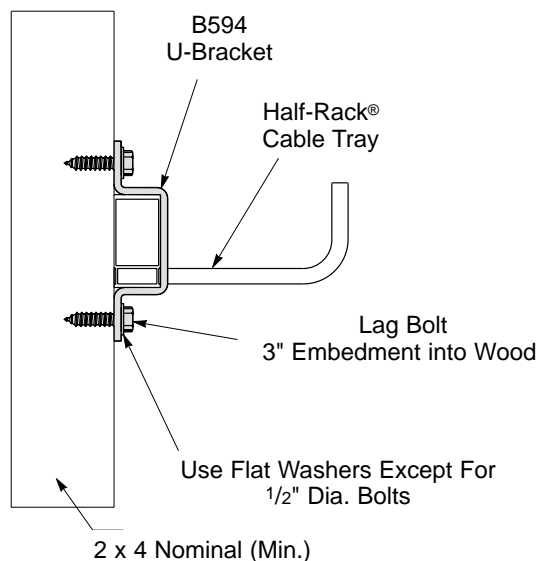

Installation Suggestions

Guidelines (cont.):

• When using Horizontal Elbow and Tee Couplings:

- Bolt “U” bracket around tray center rail with coupling bar on bottom of center rail for DATA-TRACK® & HALF-RACK®, and top of center rail for VERTI-RACK® & MULTI-TIER HALF-RACK®.
- Attach pivot connector to branch tray using included bolt, and support tray with clevis hanger within 2 ft of coupling. (May also attach to ATR by first removing captive nut.)
- Adjust pivot connector to desired position and tighten all hardware.

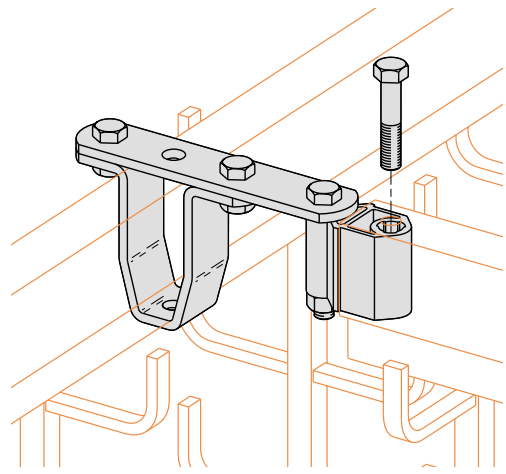
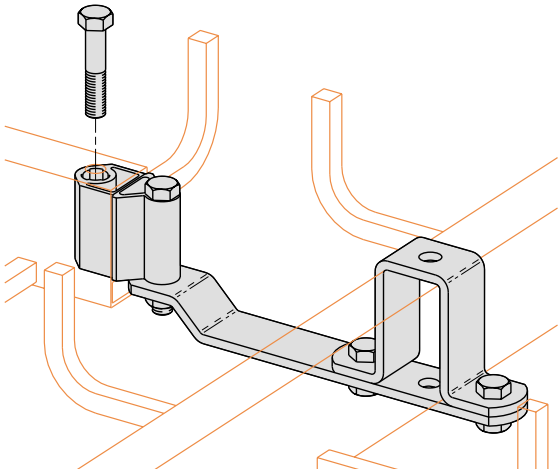

• When using Horizontal Cross Couplings:

- Installation is similar to elbow and tee coupling, except with two branch trays instead of one.
- Support ATR may be located through existing “U” bracket holes, by using clevis hangers within 2 ft of coupling. (May also attach to ATR by first removing captive nut.)

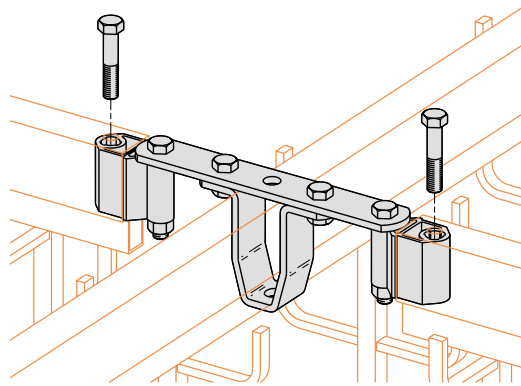
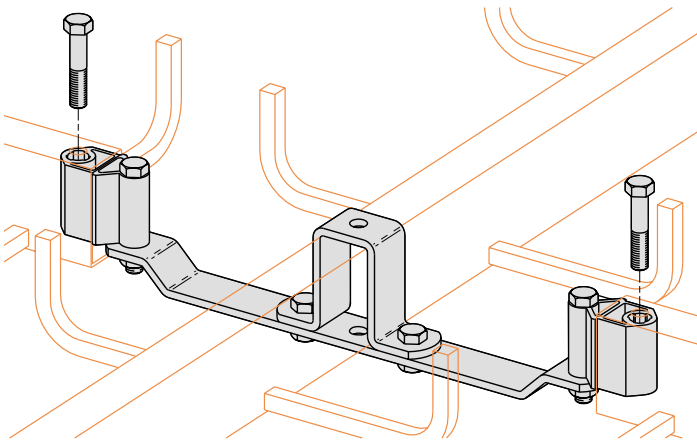

Installation Suggestions

Guidelines (cont.):

- When using Add-A-Rung® with VERTI-RACK® or MULTI-TIER HALF-RACK®:
 - See loading data for maximum center rail load capacity to determine the maximum number of tiers allowed.
 - Insert Add-A-Rung® into end of vertical trunk.
 - Install included screw through pilot hole in trunk.

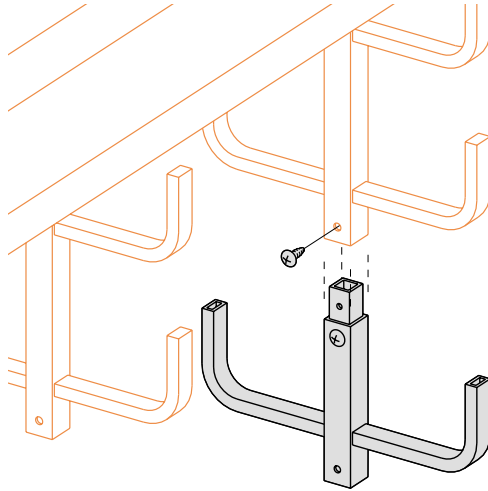

- When using Add-A-Rung® with VERTI-RACK® or MULTI-TIER HALF RACK® in Different Widths:
 - See loading data for maximum center rail load capacity to determine the maximum number of tiers in different widths allowed.
 - 3", 6", 9" and 12" wide tiers.
 - Insert Add-A-Rung® into end of vertical trunk.
 - Install included screw through pilot hole in trunk.
 - See page 16 for part number.

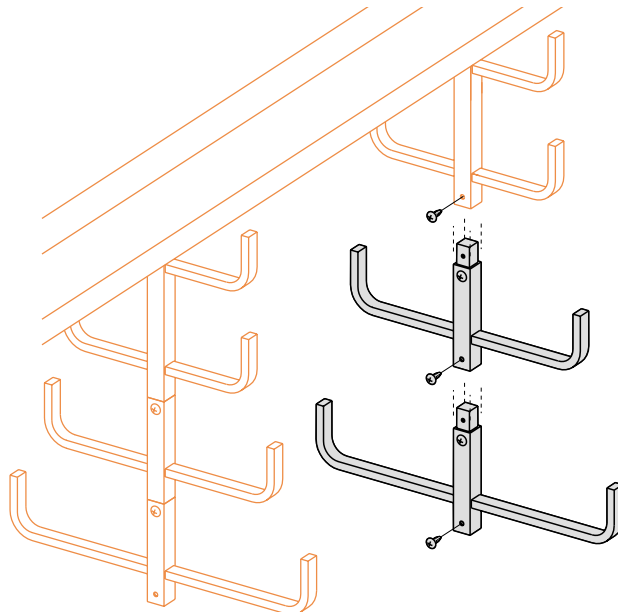

Installation Suggestions

Guidelines (cont.):

- **When using Universal Hub Fittings:**

- Position hubs with rounded edges toward cables.
- Attach pivot connectors to cable support surface using ATR, or bolt and nut through pivot hole. (If bolt and nut are used, tray must be supported using clevis hangers within 2 ft of pivot connectors.)
- Connect tray ends to pivot connectors.
- Position pivot connectors as desired and tighten hardware.
- **Warning: Do NOT use as a support for personnel!**

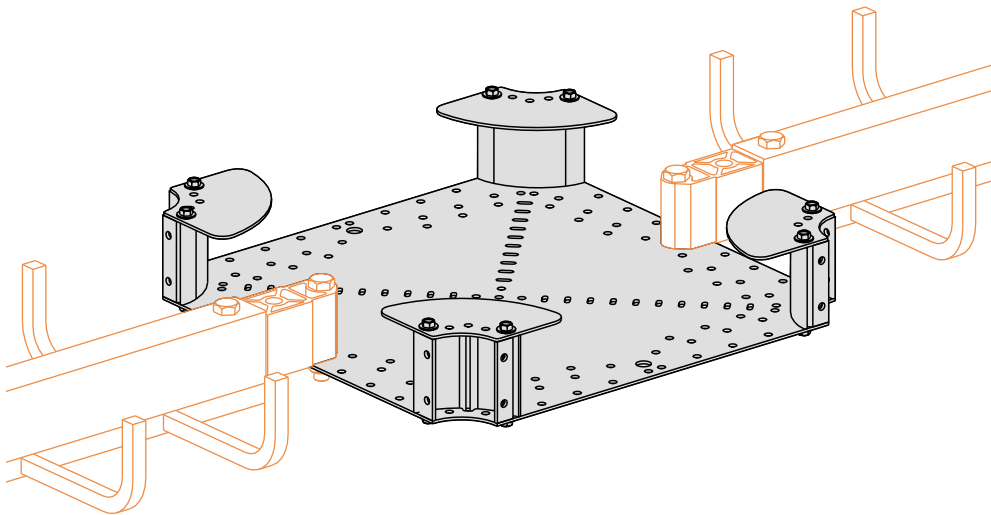

Installation Suggestions

DATA-TRACK® Bottom Rung Replacement

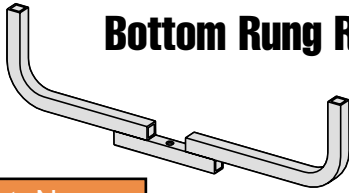

Cat. No.
C3ADB-06-RK
C3ADB-09-RK
C3ADB-12-RK
C3ADB-18-RK
C3ADB-24-RK
C4ADB-06-RK
C4ADB-09-RK
C4ADB-12-RK
C4ADB-18-RK
C4ADB-24-RK
C6ADB-06-RK
C6ADB-09-RK
C6ADB-12-RK
C6ADB-18-RK
C6ADB-24-RK



- #10 self-drilling attachments included.
- This product can act as a Rail-Riser™ for Data-Track®.

VERTI-RACK® Rung Replacement Assembly

Cat. No.
C2AV-03-RK
C2AV-06-RK
C2AV-09-RK
C2AV-12-RK

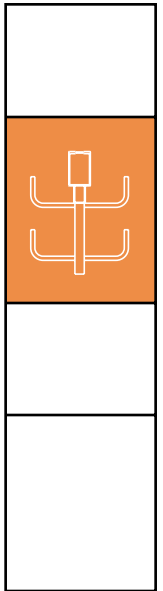
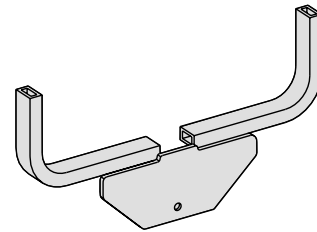

- #10 self-drilling attachments included.

HALF-RACK® Rung Replacement

Cat. No.
C3A1H-03-RK
C3A1H-06-RK
C3A1H-09-RK
C3A1H-12-RK
C4A1H-03-RK
C4A1H-06-RK
C4A1H-09-RK
C4A1H-12-RK
C6A1H-03-RK
C6A1H-06-RK
C6A1H-09-RK
C6A1H-12-RK

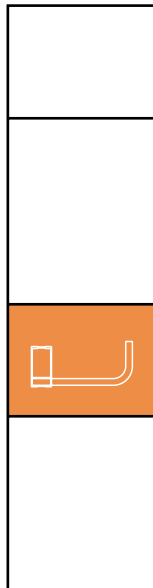
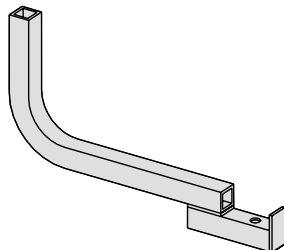

- #10 self-drilling attachments included.

MULTI-TIER HALF-RACK® Rung Replacement

Cat. No.
C3AM-03-RK
C3AM-06-RK
C3AM-09-RK
C3AM-12-RK
C4AM-03-RK
C4AM-06-RK
C4AM-09-RK
C4AM-12-RK

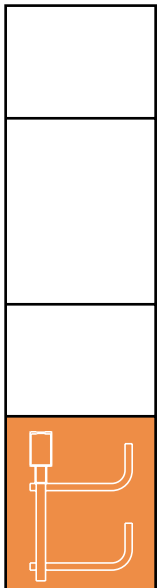
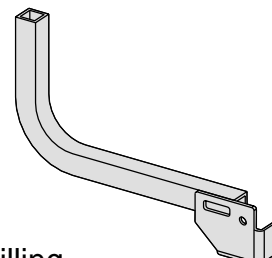

- #10 self-drilling attachments included.

Installation Suggestions

Helpful Hints

- When installing cables near a ceiling, use straight rung DATA-TRACK® and bolt to ceiling through splice holes or use “U” brackets (pg. 38).

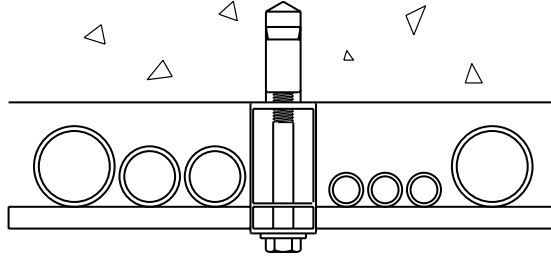

- Vertical offsets can be easily field fabricated by attaching two trays to the same ATR with one above the other.

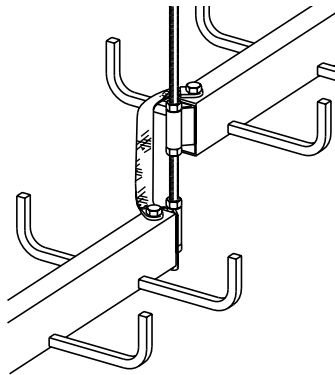

Note: Bonding jumper is required to maintain electrical continuity. (pg. 44)

Installation Suggestions

Helpful Hints (cont.):

- When Installing Cent-R-Rail® to Channel Cable Tray:

1. Data-Track®
2. Horizontal Tee Coupling
3. Channel Cable Tray Pivot Connector
4. Channel Cable Tray

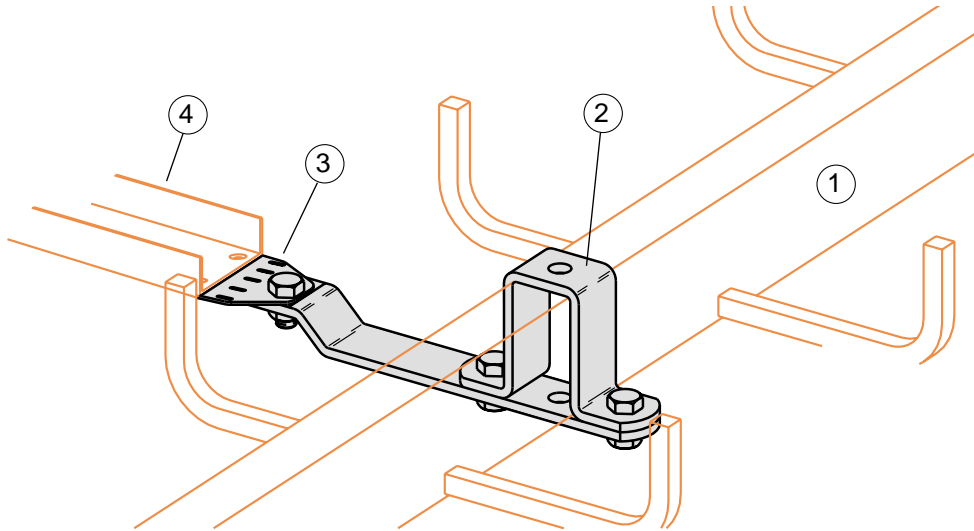

Couplings

Cat. No.		
CAC-HTD 06 P*		
Type*	Tray Width	Channel Cable Tray Width
HTD	06= 6"	03= 3" pivot connector
HTH	09= 9"	04= 4" pivot connector
HXD	12=12"	06= 6" pivot connector
OH	18=18"	
VP	24=24"	* Illustrated on page 74

Pivot connector standard finish: Aluminum

Refer to Channel Cable Tray page 75.

Cent-R-Rail® to Channel Cable Tray Connections

DATA-TRACK® TEE

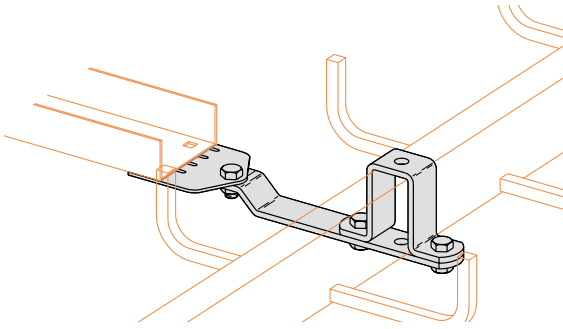

Cat. No.
CAC-HTD06P(*)
CAC-HTD09P(*)
CAC-HTD12P(*)
CAC-HTD18P(*)
CAC-HTD24P(*)

(*) 3", 4", or 6"

HALF-RACK® TEE

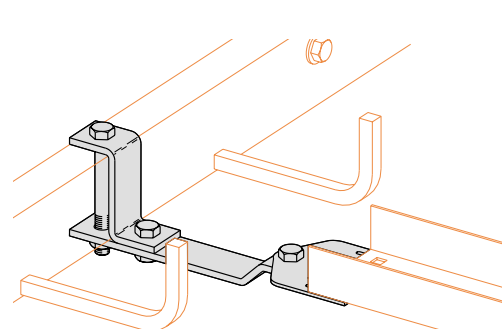

Cat. No.
CAC-HTH03P(*)
CAC-HTH06P(*)
CAC-HTH09P(*)
CAC-HTH12P(*)

(*) 3", 4", or 6"

DATA-TRACK® CROSS

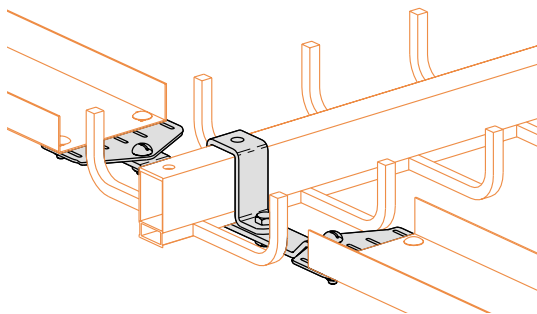

Cat. No.
CAC-HXD06P(*)
CAC-HXD09P(*)
CAC-HXD12P(*)
CAC-HXD18P(*)
CAC-HXD24P(*)

(*) 3", 4", or 6"

Horizontal Offset

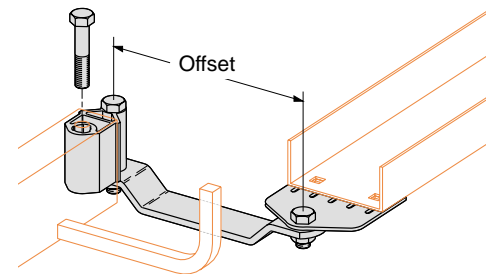

Cat. No.
CAC-OH050P(*)
CAC-OH065P(*)
CAC-OH080P(*)
CAC-OH100P(*)
CAC-OH130P(*)

(*) 3", 4", or 6"

Couplings

Cat. No.		
CAC-HTD 06 P*		
Type	Tray Width	Channel Cable Tray Width
HTD	06= 6"	03= 3" pivot connector
HTH	09= 9"	04= 4" pivot connector
HXD	12=12"	06= 6" pivot connector
OH	18=18"	
VP	24=24"	

Pivot connector standard finish: Aluminum

Vertical Coupling

Cat. No.
CAC-VP(*)

(*) 3", 4", or 6"

