

Straight Sections

DATA-TRACK®

Data-Track® Straight Section with CAS-SB Splice Hanger shown

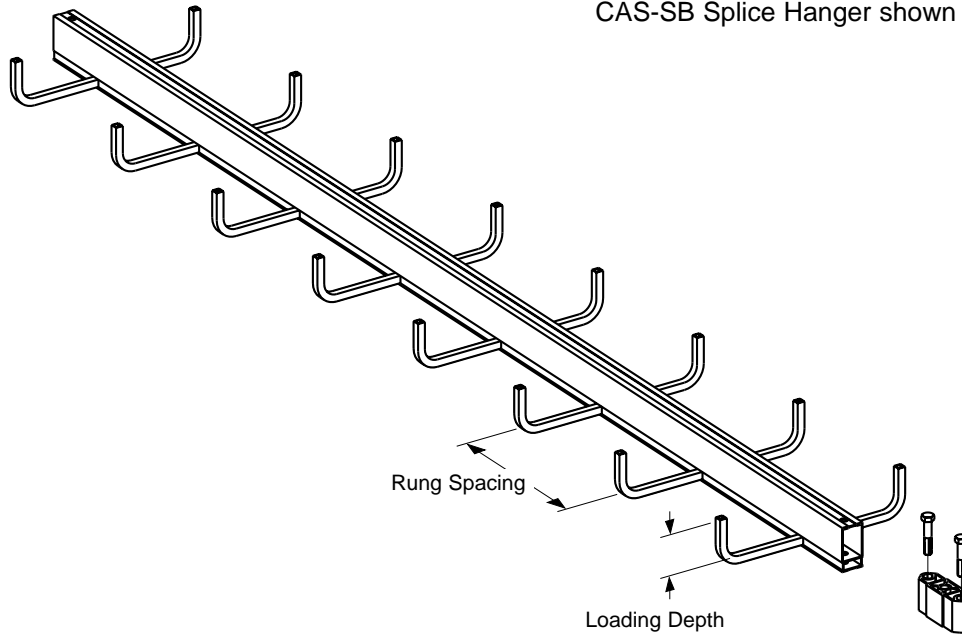

- One CAS-SB Splice Hanger provided with each straight section
- For overall height and width dimension see pages 11 & 12

Patented (see page 3)

DATA-TRACK® Straight Section Part Numbering						
			C3	A	DB	09 - 12 - 144
Series	Material	Type	Rung Spacing	Width	Length*	
C0=Straight Rung	A=Aluminum	DB=Bottom Rung	06= 6"	06= 6"	144=144"	
C3=3" Loading Depth		DT=Top Rung	09= 9"	09= 9"	120=120"	
C4=4" Loading Depth			12=12"	12=12"		
C6=6" Loading Depth				18=18"		
				24=24"		
* Actual tray lengths are 142" and 118" to allow for splice hangers						

Straight Sections



DATA-TRACK®

DATA-TRACK® LOAD CAPACITIES

Tray Width in. (mm)		Rung Spacing in. (mm)		Support Span ft. (m)								Rung * Deflection Multiplier	Avg. Empty Tray Weight lbs/ft (kg/m)	
				5 (1.5)	6 (1.8)	8 (2.4)	10 (3.0)	12 (3.7)	5 (1.5)	6 (1.8)	8 (2.4)			
6	(150)	6 (150)	646 (961)	448 (667)	252 (375)	161 (240)	112 (167)	0.00002	1.38 (2.05)					
		9 (225)	532 (792)	448 (667)	252 (375)	161 (240)	112 (167)	0.00003	1.25 (1.86)					
		12 (300)	400 (595)	400 (595)	252 (375)	161 (240)	112 (167)	0.00004	1.20 (1.79)					
9	(225)	6 (150)	532 (793)	448 (741)	252 (375)	161 (240)	112 (167)	0.00005	1.45 (2.16)					
		9 (225)	354 (527)	354 (527)	252 (375)	161 (240)	112 (167)	0.00008	1.30 (1.93)					
		12 (300)	266 (396)	266 (396)	252 (375)	161 (240)	112 (167)	0.0001	1.24 (1.85)					
12	(300)	6 (150)	400 (595)	400 (595)	252 (375)	161 (240)	112 (167)	0.0002	1.53 (2.28)					
		9 (225)	266 (396)	266 (396)	252 (375)	161 (240)	112 (167)	0.0002	1.35 (2.01)					
		12 (300)	200 (298)	200 (298)	200 (298)	161 (240)	112 (167)	0.0003	1.28 (1.90)					
18	(450)	6 (150)	266 (396)	266 (396)	252 (375)	161 (240)	112 (167)	0.0005	1.69 (2.51)					
		9 (225)	178 (265)	178 (265)	178 (265)	161 (240)	112 (167)	0.0007	1.46 (2.17)					
		12 (300)	134 (199)	134 (199)	134 (199)	134 (199)	112 (167)	0.0009	1.35 (2.01)					
24	(600)	6 (150)	200 (298)	200 (298)	200 (298)	161 (240)	112 (167)	0.0011	1.85 (2.75)					
		9 (225)	134 (199)	134 (199)	134 (199)	134 (199)	112 (167)	0.0017	1.56 (2.32)					
		12 (300)	100 (149)	100 (149)	100 (149)	100 (149)	100 (149)	0.0022	1.43 (2.13)					

Safety Factor = 1.5 for load capacities

For unbalanced load information see appendix page A-3

For Seismic Restraint Systems see appendix page A-4

	Support Span (feet)				
	5	6	8	10	12
Center Rail Deflection Multiplier*	0.0012	0.0025	0.0079	0.0192	0.0397

* Deflection multipliers are given for English units. To determine deflection in millimeters, first calculate deflection in inches and then multiply by 25.4.

To calculate the center rail simple beam deflection at mid span in inches for a specific support span (ft), multiply the "center rail deflection multiplier" for that span by the load in lbs/ft that will be installed in the cable tray.

Example: The center rail deflection for 50 lbs/ft supported every 12 ft = 50 x .0397 = 2.0 inches.

Note: When trays are used in continuous spans, the deflection is reduced by as much as 50%.

To calculate the rung deflection in inches for a specific tray width (in.) and rung spacing (in.), multiply the rung deflection multiplier for that width and rung spacing by the load in lbs/ft that will be installed in the cable tray.

Example: The rung deflection for 50 lbs/ft in a 12" wide tray with 9" rung spacing = 50 x .0002 = .01 inches.

Note: The rung deflection multiplier is based on a uniformly distributed load.

Section Property		Center Rail	Rungs
Area	in ²	0.88	0.13
	(cm ²)	(5.68)	(0.84)
Sx	in ³	0.70	0.02
	(cm ³)	(11.49)	(0.31)
Ix	in ⁴	1.17	0.005
	(cm ⁴)	(48.87)	(0.21)

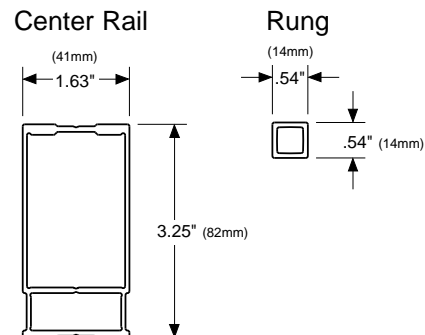

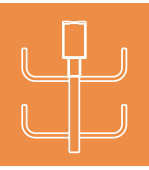

Straight Sections

VERTI-RACK®

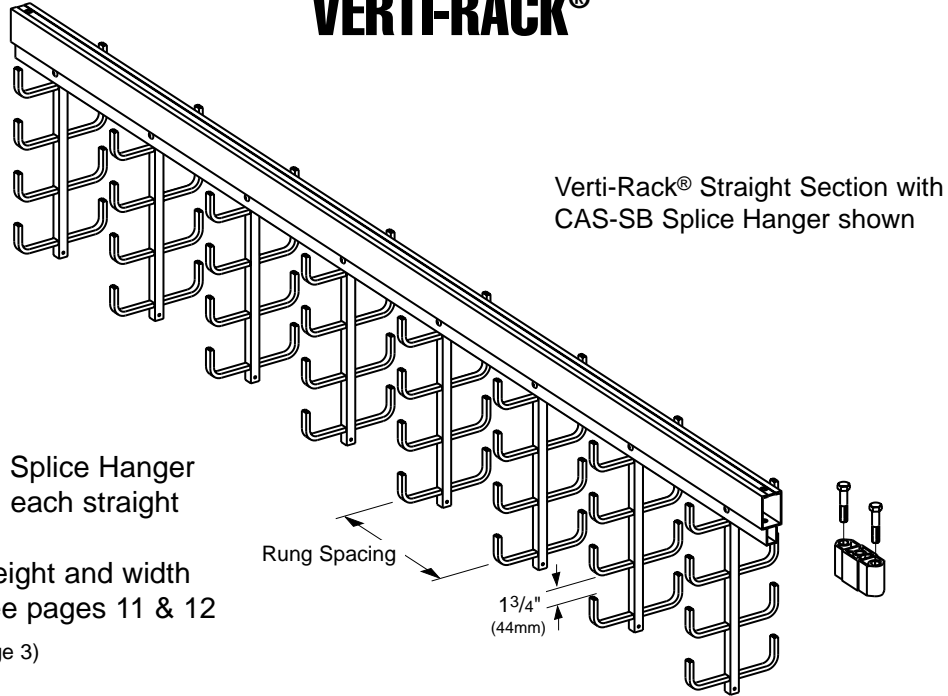

- One CAS-SB Splice Hanger provided with each straight section
 - For overall height and width dimension see pages 11 & 12
- Patented (see page 3)

VERTI-RACK® Straight Section Part Numbering

C2 A 4V 12 - 09 - 144

Series	Material	Type†	Rung Spacing	Width†	Length*
C0=Straight Rung C2=2" Loading Depth	A=Aluminum	2V=2 tier 3V=3 tier 4V=4 tier 5V=5 tier 6V=6 tier	06= 6" 09= 9" 12=12" (Specials available)	03= 3" 06= 6" 09= 9" 12=12"	144=144" 120=120"

* Actual tray lengths are 142" and 118" to allow for splice hangers
 † For inverted, multiple or special sizes and widths see appendix pages A-5, A-6, A-7

Expand your VERTI-RACK® system with ADD-A-RUNG®

- Attaches to bottom of existing tray
- Shipped with required hardware

ADD-A-RUNG® Part Numbering

CAR-2 V 2 12

No. of Tiers	Loading Depth	Width
1=1 tier 2=2 tier	0=Straight Rung 2=2" Loading Depth	03= 3" 06= 6" 09= 9" 12=12"

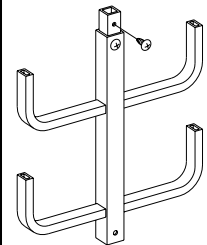

Note: Not to exceed 100 lbs/ft on 12 ft span, 225 lbs/ft on 8 ft span.

Straight Sections

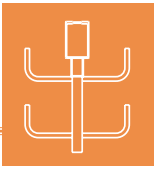

VERTI-RACK®

Support Span		Total System Load Capacities		Center Rail* Deflection
ft	(m)	lbs/ft	(kg/m)	Multiplier
5	(1.5)	300	(450)	0.0010
6	(1.8)	300	(450)	0.0020
8	(2.4)	225	(335)	0.0063
10	(3.0)	144	(214)	0.0155
12	(3.7)	100	(149)	0.0321

Tray Width		Rung Spacing		Per Tier Load Capacity		Rung* Deflection	Avg. Empty Tray Weight	
in.	(mm)	in.	(mm)	lbs/ft	(kg/m)	Multiplier	lbs/ft	(kg/m)
3	(75)	6	(150)	608	(905)	0.00001	2.09	(3.11)
		9	(225)	408	(607)	0.00002	1.72	(2.56)
		12	(300)	304	(452)	0.00002	1.55	(2.31)
6	(150)	6	(150)	304	(452)	0.0001	2.31	(3.44)
		9	(225)	204	(304)	0.0002	1.86	(2.77)
		12	(300)	152	(226)	0.0002	1.66	(2.47)
9	(225)	6	(150)	203	(302)	0.0003	2.53	(3.76)
		9	(225)	136	(202)	0.0004	2.00	(2.98)
		12	(300)	102	(152)	0.0005	1.77	(2.63)
12	(300)	6	(150)	152	(226)	0.0006	2.75	(4.09)
		9	(225)	102	(152)	0.0009	2.14	(3.18)
		12	(300)	76	(113)	0.0012	1.88	(2.80)

Safety Factor = 1.5 for load capacities

* Deflection multipliers are given for English units. To determine deflection in millimeters, first calculate deflection in inches and then multiply by 25.4.

Example: The center rail deflection for 50 lbs/ft supported every 12 ft = $50 \times .0321 = 1.6$ inches.

Example: The rung deflection for 50 lbs/ft in a 12" wide tray with 9" rung spacing = $50 \times .0009 = .05$ inches.

Section Property		Center Rail	Rungs	Trunk
Area	in ²	0.88	0.09	0.18
	(cm ²)	(5.68)	(0.61)	(1.16)
Sx	in ³	0.56	0.01	N/A
	(cm ³)	(9.15)	(0.12)	(N/A)
Ix	in ⁴	1.27	0.001	N/A
	(cm ⁴)	(52.99)	(0.04)	(N/A)

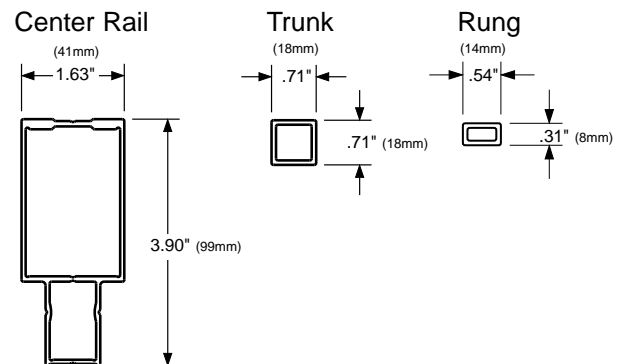



Straight Sections

HALF-RACK®

Half-Rack® Straight Section with CAS-SB Splice Hanger shown

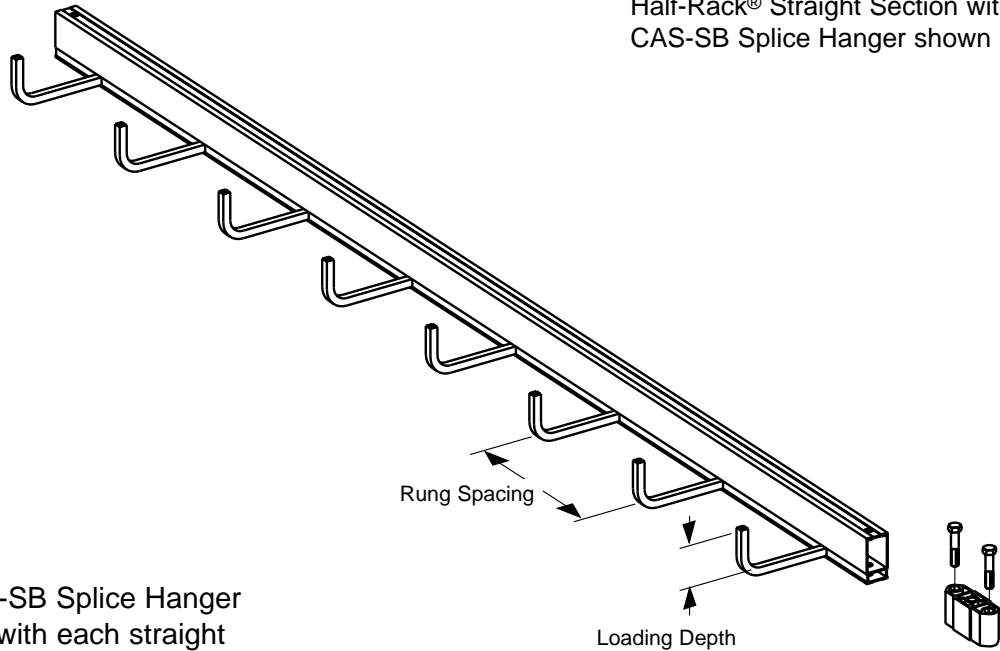

- One CAS-SB Splice Hanger provided with each straight section
- For overall height and width dimension see pages 11 & 13

Patented (see page 3)

HALF-RACK® Straight Section Part Numbering						
		C3	A	1H	09 - 12 - 144	
Series	Material				Rung Spacing	Width
C0=Straight Rung	A=Aluminum				06= 6"	03= 3"
C3=3" Loading Depth					09= 9"	06= 6"
C4=4" Loading Depth					12=12"	09= 9"
C6=6" Loading Depth						12=12"
						Length*
						144=144"
						120=120"

* Actual tray lengths are 142" and 118" to allow for splice hangers

Straight Sections



HALF-RACK®

Half-Rack® Loading Guidelines

• Support Locations

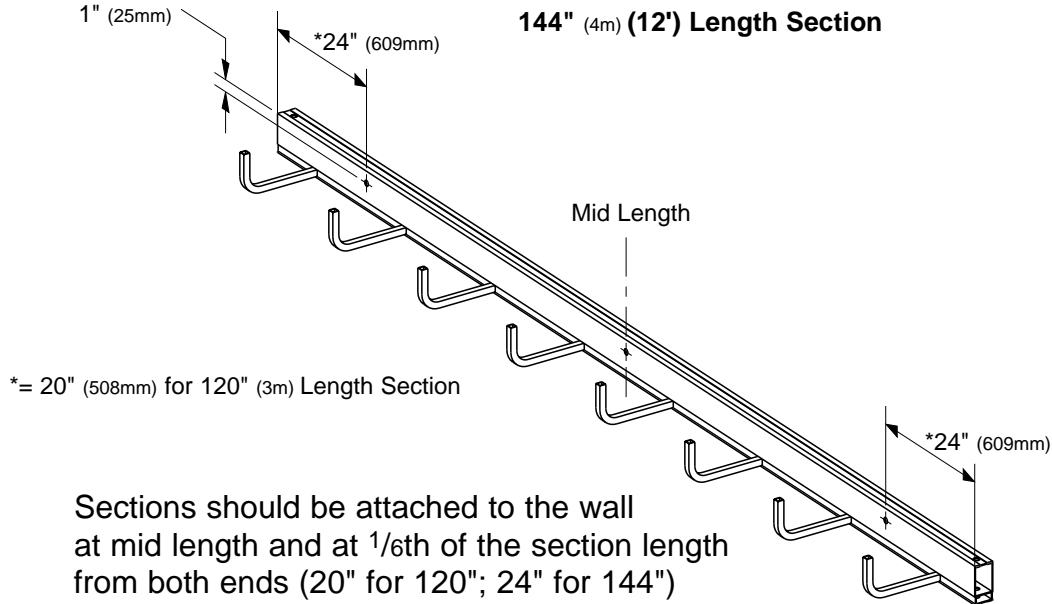

* = 20" (508mm) for 120" (3m) Length Section

Sections should be attached to the wall at mid length and at $\frac{1}{6}$ th of the section length from both ends (20" for 120"; 24" for 144")

- No spacers needed
- For Half-Rack® wall attachment options see page 66

• Loading Recommendations

- CSA classified A-3M
- 50 lbs/ft (74kg/m) maximum based on $\frac{3}{4}$ " (19mm) rung deflection



For Seismic Restraint Systems see appendix page A-4

Section Property		Center Rail	Rungs
Area	in ²	0.88	0.13
	(cm ²)	(5.68)	(0.84)
S _x	in ³	0.70	0.02
	(cm ³)	(11.49)	(0.31)
I _x	in ⁴	1.17	0.005
	(cm ⁴)	(48.87)	(0.21)

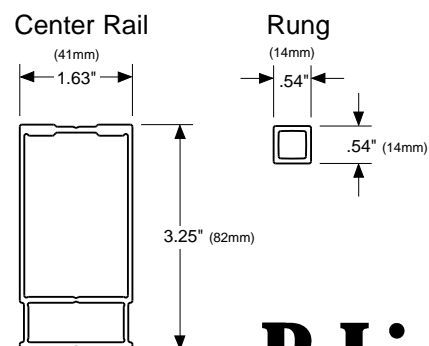

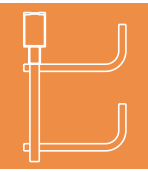

Straight Sections

MULTI-TIER HALF-RACK®

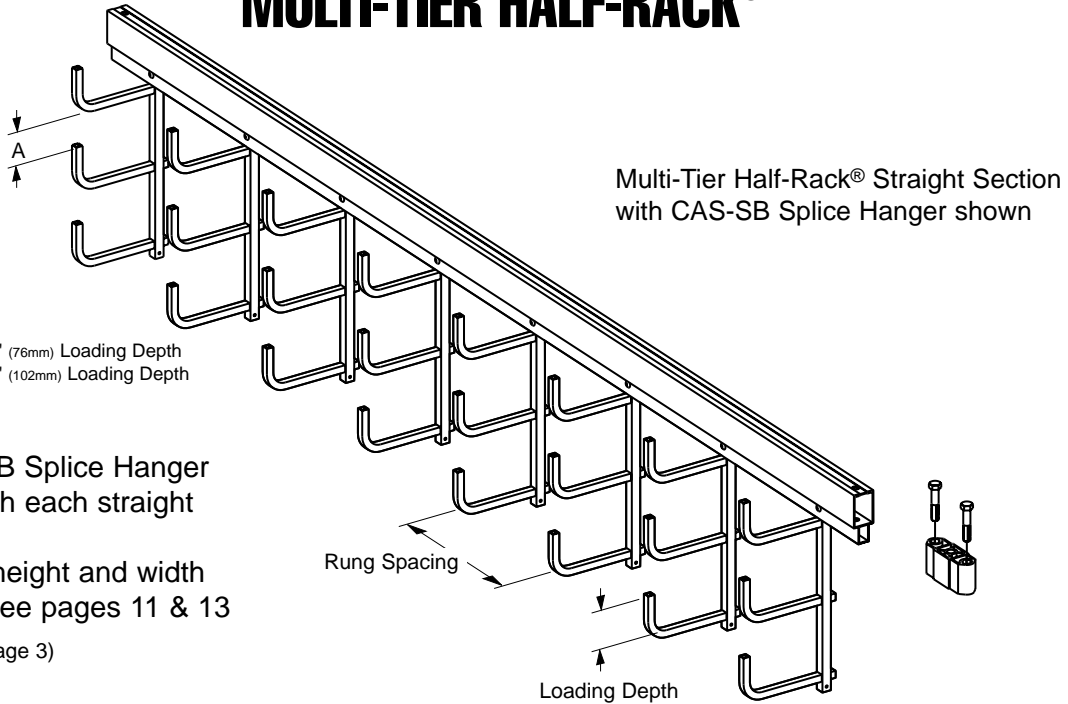

A = 2⁵/₈" (67mm) for 3" (76mm) Loading Depth
 = 1³/₄" (44mm) for 4" (102mm) Loading Depth

- One CAS-SB Splice Hanger provided with each straight section
- For overall height and width dimension see pages 11 & 13

Patented (see page 3)

MULTI-TIER HALF-RACK® Straight Section Part Numbering					
Series	Material	Type	Rung Spacing	Width†	Length*
C0=Straight Rung	A=Aluminum	2M=2 tier	06= 6"	03= 3"	144=144"
C3=3" Loading Depth		3M=3 tier	09= 9"	06= 6"	120=120"
C4=4" Loading Depth		4M=4 tier	12=12"	09= 9"	
			(Specials available)	12=12"	

* Actual tray lengths are 142" and 118" to allow for splice hangers
 † For multiple widths see appendix pages A-5 - A-6

Expand your MULTI-TIER HALF-RACK® system with ADD-A-RUNG®

- Attaches to bottom of existing tray
- Shipped with required hardware

ADD-A-RUNG® Part Numbering		
No. of Tiers	Loading Depth	Width
1=1 tier	0=Straight Rung	03= 3"
2=2 tier	3=3" Loading Depth	06= 6"
	4=4" Loading Depth	09= 9"
		12=12"

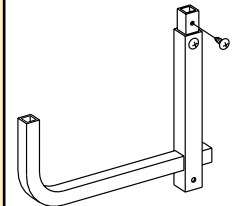

Note: Not to exceed 100 lbs/ft on 12 ft span, 225 lbs/ft on 8 ft span.

Straight Sections

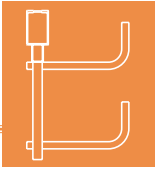

MULTI-TIER HALF-RACK®

Multi-Tier Half-Rack® Loading Guidelines

• Support Locations

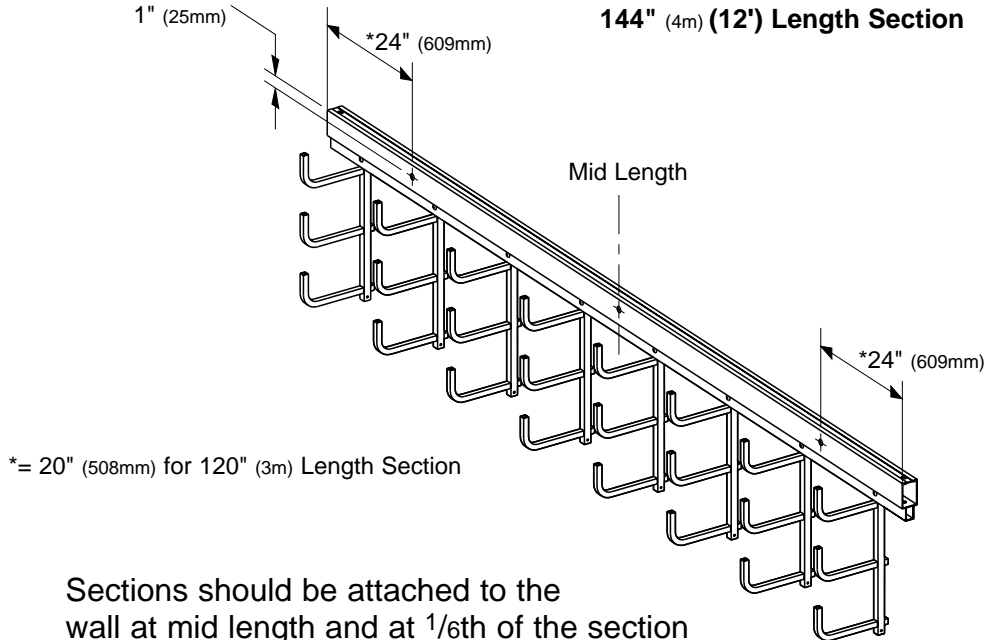

Sections should be attached to the wall at mid length and at 1/6th of the section length from both ends (20" for 120"; 24" for 144")

- No spacers needed
- For Multi-Tier Half-Rack® wall attachment options see page 67

• Loading Recommendations

- 50 lbs/ft (74kg/m) per tier maximum based on 3/4" (19mm) rung deflection



Half-Rack® shown

For Seismic Restraint Systems see appendix page A-4

Section Property		Center Rail	Rungs	Trunk
Area	in ²	0.88	0.13	0.18
	(cm ²)	(5.68)	(0.84)	(1.16)
Sx	in ³	0.56	0.02	N/A
	(cm ³)	(9.15)	(0.31)	(N/A)
Ix	in ⁴	1.27	0.005	N/A
	(cm ⁴)	(52.99)	(0.21)	(N/A)

Center Rail

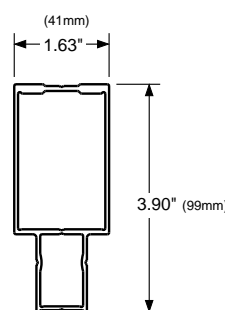

Trunk

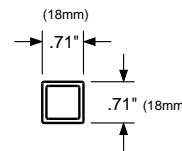

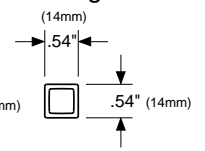

Rung



Key to Using Application Bar

The parts in the following catalog sections can be used with one or more of the Cent-R-Rail® systems. We have provided the following application bar to indicate the systems each item is compatible with.

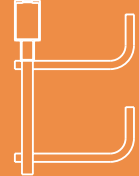
	Indicates compatibility with DATA-TRACK® When Icon appears in box
	Indicates compatibility with VERTI-RACK® When Icon appears in box
	Indicates compatibility with HALF-RACK® When Icon appears in box
	Indicates compatibility with MULTI-TIER HALF-RACK® When Icon appears in box

Example:

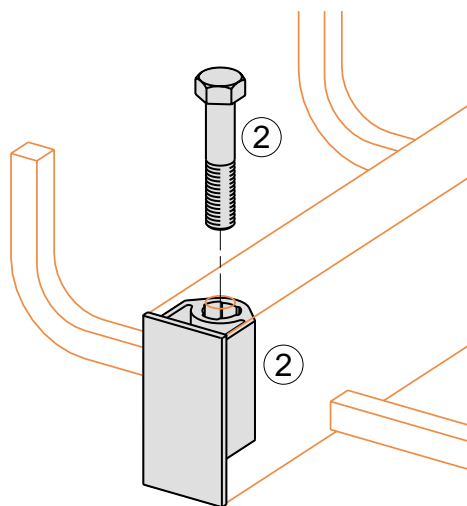
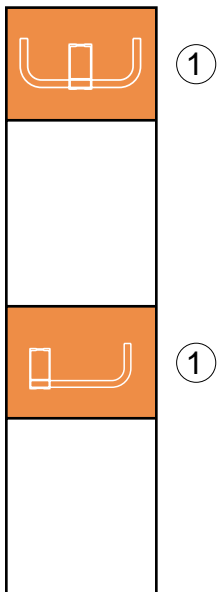

Aluminum Center Rail End Cap

Cat. No.
CAM-EC10B

- ① Application bar indicates that this part can be used with DATA-TRACK® or HALF-RACK®, but not with VERTI-RACK® or MULTI-TIER HALF-RACK®
- ② The shaded items illustrated in black lines are provided

Straight Connectors

Qwik-Bolt® Splice Hanger

Cat. No.
CAS-SB

Patented (see page 3)

- One splice included with each straight section
- Bolts screw directly into splice, minimizing hardware
- Splice protects cables from center rail edges
- Vertical hardware removes hardware from cable fill area
- Shipped assembled with required hardware
- Designed to install with 1/2" ATR
- UL classified for grounding - 1000 amps

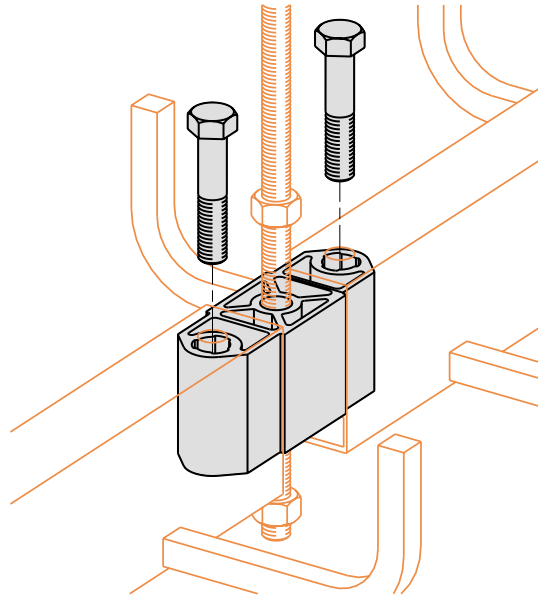

Qwik-Bolt® No Gap Splice

Cat. No.
CAS-NG

Patented (see page 3)

- A straight splice option
- Bolts screw directly into splice, minimizing hardware
- Vertical hardware removes hardware from cable fill area
- Shipped assembled with required hardware
- UL classified for grounding - 1000 amps
- Straight section length (using this splice) is 142 or 118 inches
- For use where ATR is not required through the splice hanger

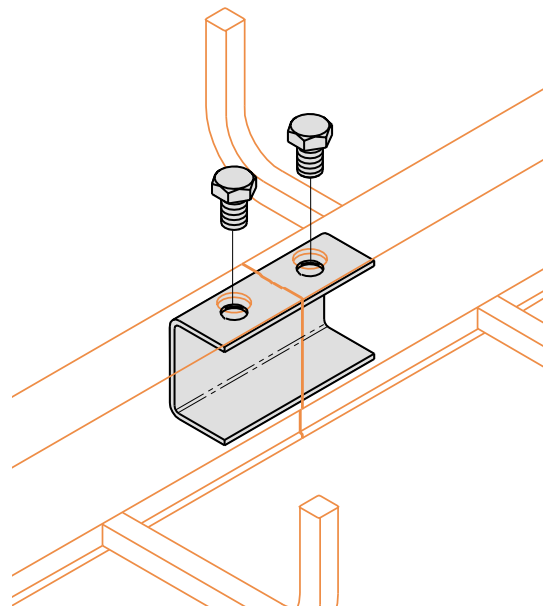

Note: All connectors are aluminum material and sized for 1/2" zinc plated steel hardware, unless otherwise specified.

Straight Connectors

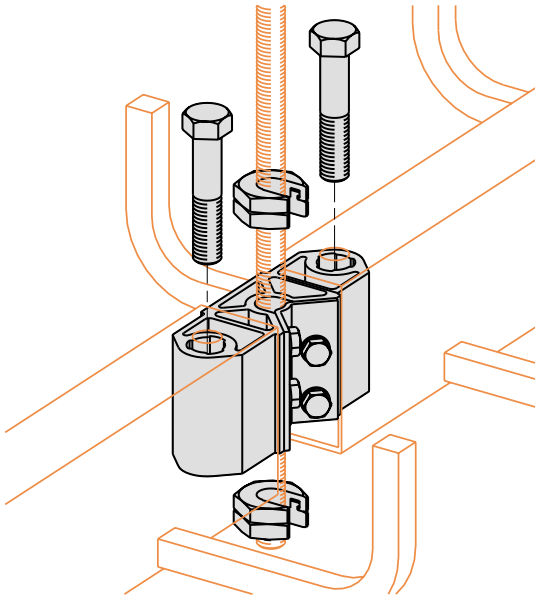
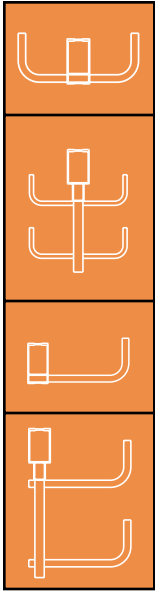

Clamp-On Splice Hanger

Cat. No.
CAS-CB

Patented (see page 3)

- Side mounts to existing 1/2" ATR
- Qwik-Bolt® design
- Shipped with required hardware
- UL classified for grounding - 1000 amps

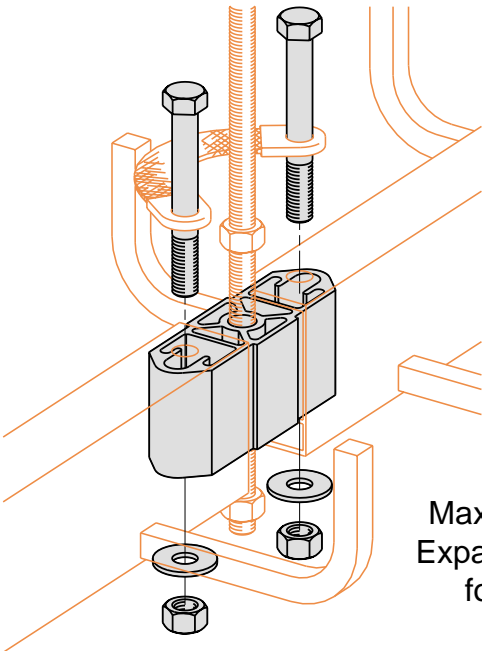
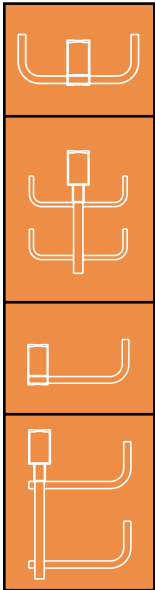

Expansion Splice Hanger

Cat. No.	Tray Type
CAS-EB1	DATA-TRACK® & HALF-RACK®
CAS-EB2	VERTI-RACK® & MULTI-TIER HALF-RACK®

Patented (see page 3)

- Allows for 1" (25mm) of tray expansion and contraction
- Shipped with required hardware
- Order grounding jumper CAM-GJ separately (see page 44)

Table 1
Maximum Spacing Between
Expansion Joints that Provide
for 1" (25mm) Movement

Temperature Differential		Aluminum	
°F	(°C)	ft	(m)
25	(14)	260	(79)
50	(28)	130	(40)
75	(42)	87	(27)
100	(56)	65	(20)
125	(69)	52	(16)
150	(83)	43	(13)
175	(97)	37	(11)

It is important that thermal contraction and expansion be considered when installing cable tray systems. The length of the straight cable tray runs and the temperature differential govern the number of expansion splice plates required (See Table 1).

Note: All connectors are aluminum material and sized for 1/2" zinc plated steel hardware, unless otherwise specified.

Straight Connectors

Horizontal Offset Coupling

Cat. No.	Offset	
	in.	(mm)
CAC-OH050B	5.0	(125)
CAC-OH065B	6.5	(165)
CAC-OH080B	8.0	(200)
CAC-OH100B	10.0	(250)
CAC-OH130B	13.0	(330)

Patented (see page 3)

Refer to tray widths on pg. 11 to determine offset needed

- Designed to provide horizontal offset
- Ideal for connecting DATA-TRACK® to HALF-RACK®
- Pivoting connections
- Qwik-Bolt® design
- Shipped assembled with required hardware
- UL classified for grounding - 1000 amps
- 7/8" (22mm) adjustment on offset

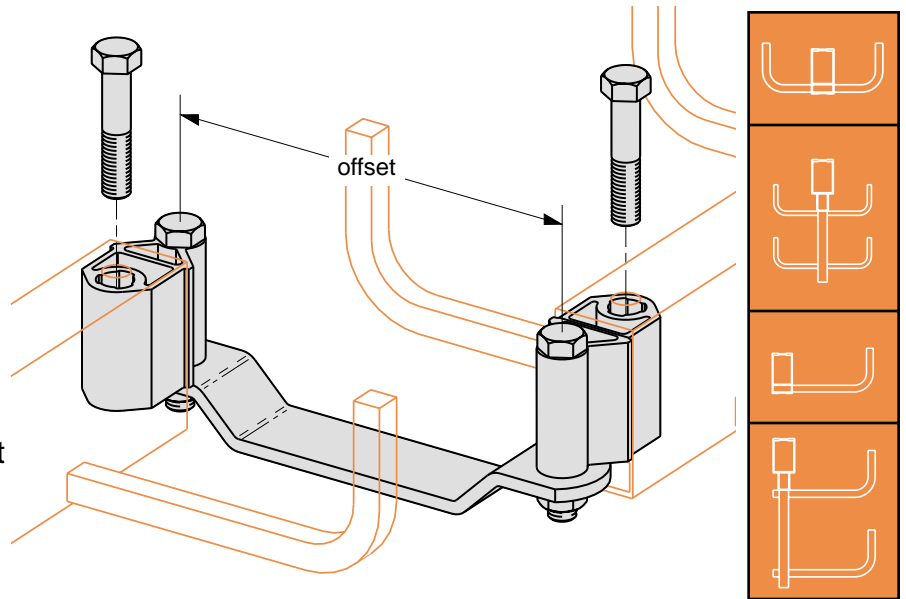

Vertical Offset Coupling

Cat. No.	Offset	
	in.	(mm)
CAC-OV030B	3.0	(75)
CAC-OV060B	6.0	(150)

Patented (see page 3)

- Designed to provide vertical offset
- Pivoting connections
- Qwik-Bolt® design
- Shipped assembled with required hardware
- UL classified for grounding - 1000 amps

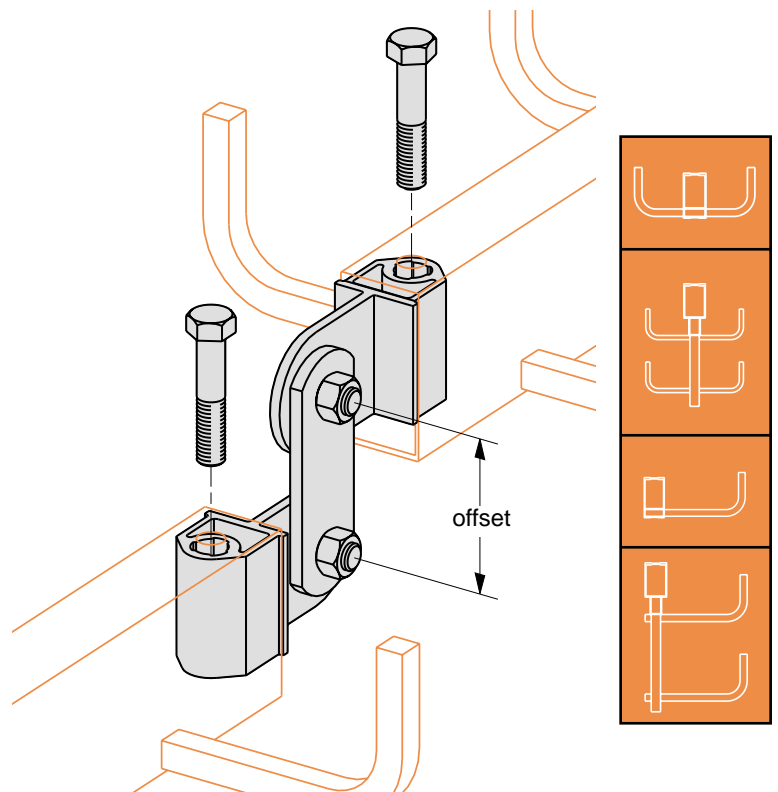

Note: All connectors are aluminum material and sized for 1/2" zinc plated steel hardware, unless otherwise specified.

Horizontal Elbow

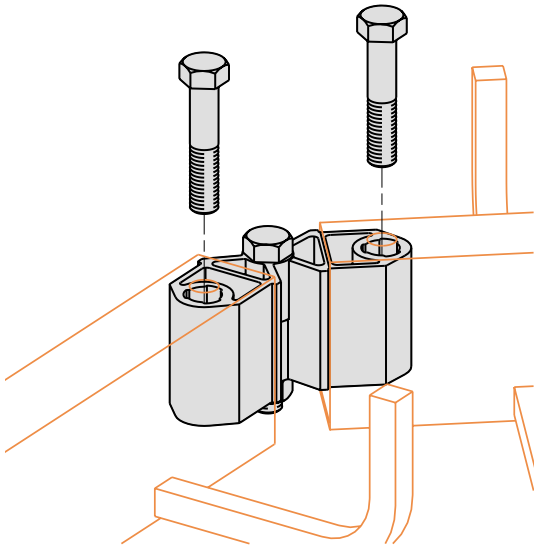
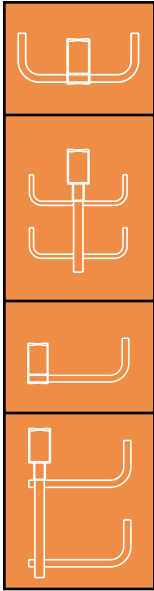

Horizontal Adjustable Splice

Cat. No.
CAS-HB

Patented (see page 3)

- Allows random angle horizontal bend
- Also can be used to connect straight sections at mid-run locations
- Qwik-Bolt® design
- Shipped assembled with required hardware
- UL classified for grounding - 1000 amps

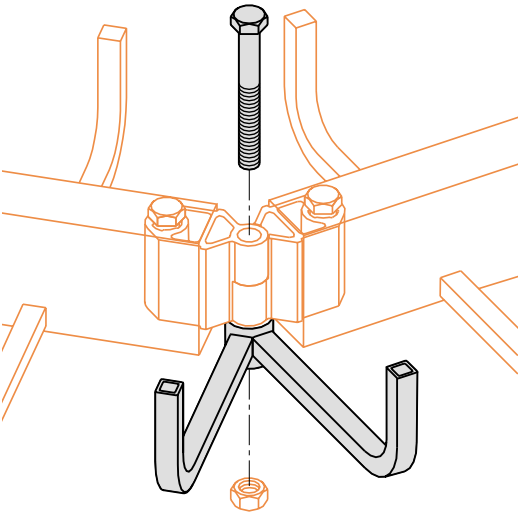
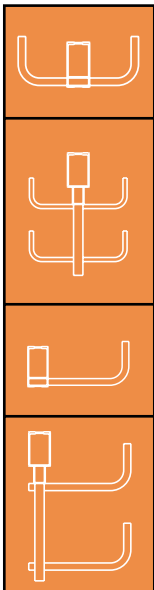

Horizontal Bend Rung Support

Cat. No.
CAR-H3-06
CAR-H3-09
CAR-H3-12
CAR-H3-18
CAR-H3-24
CAR-H4-06
CAR-H4-09
CAR-H4-12
CAR-H4-18
CAR-H4-24
CAR-H6-06
CAR-H6-09
CAR-H6-12
CAR-H6-18
CAR-H6-24

Cat. No.	
CAR-H3-06	
Loading Depth	Tray Width
0=0"	06 = 6"
3=3"	09 = 9"
4=4"	12 = 12"
6=6"	18 = 18"
	24 = 24"

- Use with CAS-HB
- For additional cable support on the outside of bends
- Select fill depth and width required
- Shipped with required hardware (1 pc. HHCS - 1/2" x 4" znplt)
- Rungs set at 45° angle

Note: All connectors are aluminum material and sized for 1/2" zinc plated steel hardware, unless otherwise specified.

Horizontal Elbow & Tee Connectors

DATA-TRACK®

Horizontal Tee Coupling

Tray 1 Width		Cat. No.	L	
in.	(mm)		in.	(mm)
6	(150)	CAC-HTD06B	5.0	(125)
9	(225)	CAC-HTD09B	6.5	(165)
12	(300)	CAC-HTD12B	8.0	(200)
18	(450)	CAC-HTD18B	10.0	(250)
24	(600)	CAC-HTD24B	13.0	(330)

Patented (see page 3)

- Used to make tee, elbow or wye
- Allows random attachment to center rail without drilling
- Pivoting connection
- Qwik-Bolt® Design
- Shipped assembled with required hardware
- 9/16" (14mm) hole provided for optional support ATR
- 7/16" (11mm) adjustment slot
- UL classified for grounding - 1000 amps

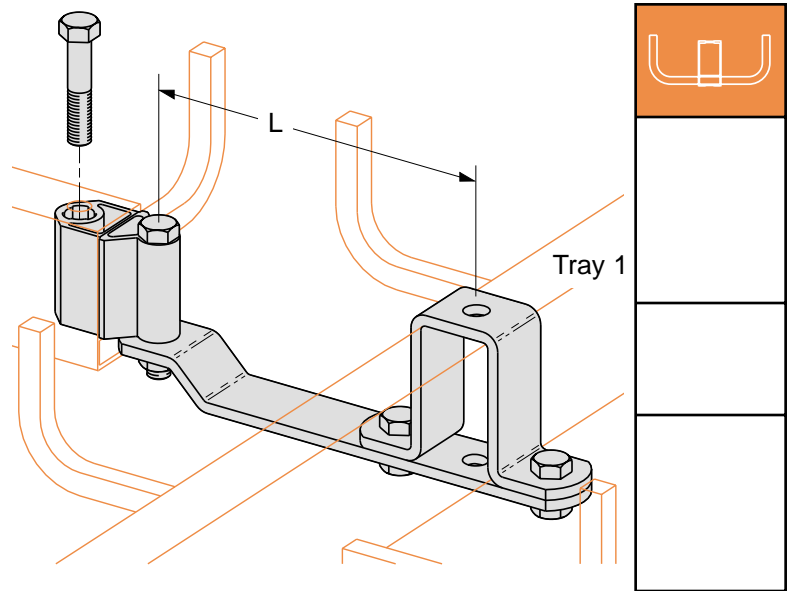

VERTI-RACK®

Horizontal Tee Coupling

Tray 1 Width		Cat. No.	L	
in.	(mm)		in.	(mm)
3	(75)	CAC-HTV03B	3.0	(75)
6	(150)	CAC-HTV06B	4.5	(115)
9	(225)	CAC-HTV09B	6.0	(150)
12	(300)	CAC-HTV12B	7.5	(190)

Patented (see page 3)

- Used to make tee, elbow or wye
- Allows random attachment to center rail without drilling
- Pivoting connection
- Qwik-Bolt® design
- Shipped assembled with required hardware
- 7/16" (11mm) adjustment slot
- UL classified for grounding - 1000 amps

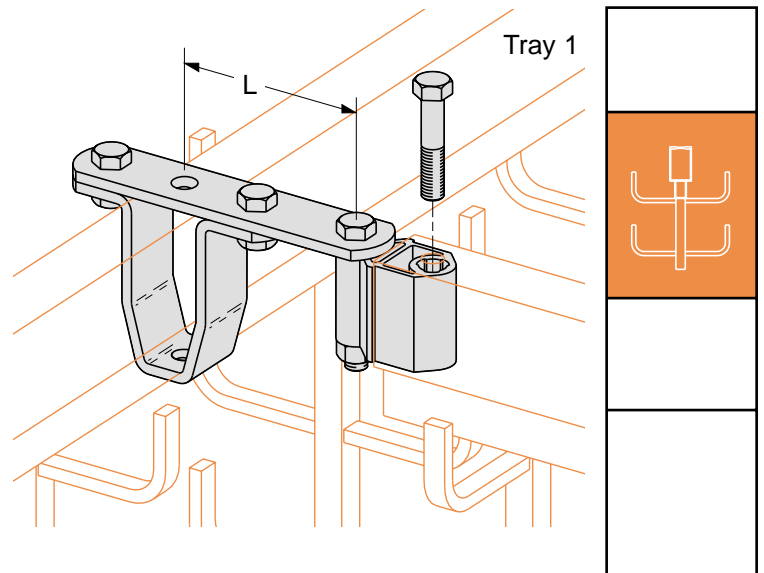

Note: All connectors are aluminum material and sized for 1/2" zinc plated steel hardware, unless otherwise specified.

Horizontal Elbow & Tee Connectors

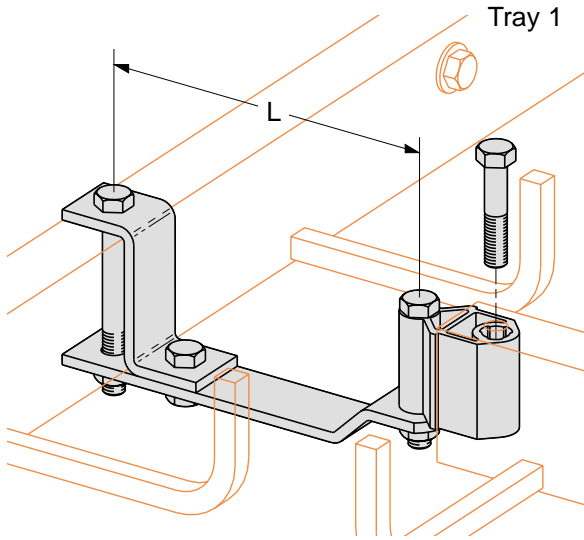
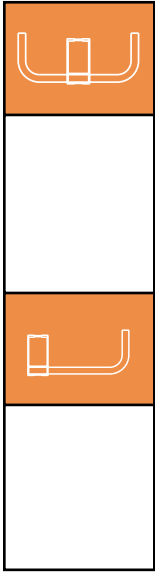

HALF-RACK® Horizontal Tee Coupling

Tray 1 Width		Cat. No.	L	
in.	(mm)		in.	(mm)
3	(75)	CAC-HTH03B	5	(125)
6	(150)	CAC-HTH06B	8	(200)
9	(225)	CAC-HTH09B	11	(275)
12	(300)	CAC-HTH12B	14	(355)

Patented (see page 3)

- Used to make tee, elbow or wye
- Allows random attachment to center rail
- Pivoting connection
- Qwik-Bolt® design
- Shipped assembled with required hardware
- UL classified for grounding - 1000 amps

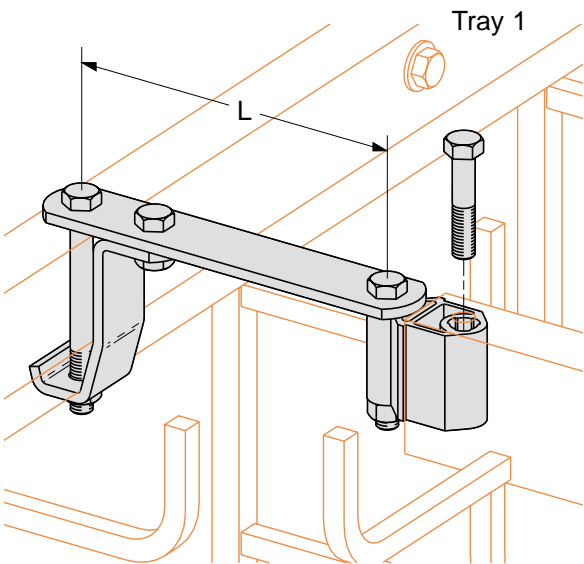
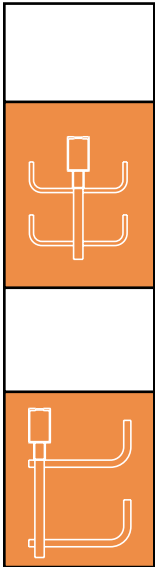

MULTI-TIER HALF-RACK® Horizontal Tee Coupling

Tray 1 Width		Cat. No.	L	
in.	(mm)		in.	(mm)
3	(75)	CAC-HTM03B	5	(125)
6	(150)	CAC-HTM06B	8	(200)
9	(225)	CAC-HTM09B	11	(275)
12	(300)	CAC-HTM12B	14	(355)

Patented (see page 3)

- Used to make tee, elbow or wye
- Allows random attachment to center rail
- Pivoting connection
- Qwik-Bolt® design
- Shipped assembled with required hardware
- UL classified for grounding - 1000 amps

Horizontal Cross Connectors

DATA-TRACK®

Horizontal Cross Coupling

Tray 1 Width		Cat. No.	L	
in.	(mm)		in.	(mm)
6	(150)	CAC-HXD06B	10	(250)
9	(225)	CAC-HXD09B	13	(330)
12	(300)	CAC-HXD12B	16	(400)
18	(450)	CAC-HXD18B	20	(500)
24	(600)	CAC-HXD24B	26	(650)

Patented (see page 3)

- Allows random attachment to center rail without drilling
- Pivoting connections
- Qwik-Bolt® design
- Shipped assembled with required hardware
- 9/16" (14mm) hole provided for optional support ATR
- UL classified for grounding - 1000 amps

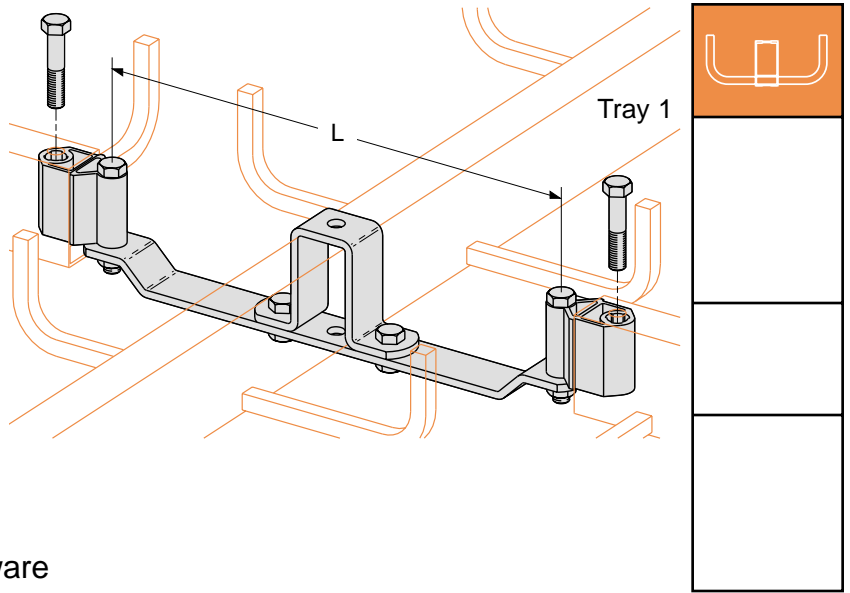

VERTI-RACK®

Horizontal Cross Coupling

Tray 1 Width		Cat. No.	L	
in.	(mm)		in.	(mm)
3	(75)	CAC-HXV03B	6	(150)
6	(150)	CAC-HXV06B	9	(225)
9	(225)	CAC-HXV09B	12	(300)
12	(300)	CAC-HXV12B	15	(375)

Patented (see page 3)

- Allows random attachment to center rail without drilling
- Pivoting connections
- Qwik-Bolt® design
- Shipped assembled with required hardware
- 9/16" (14mm) hole provided for optional support ATR
- UL classified for grounding - 1000 amps

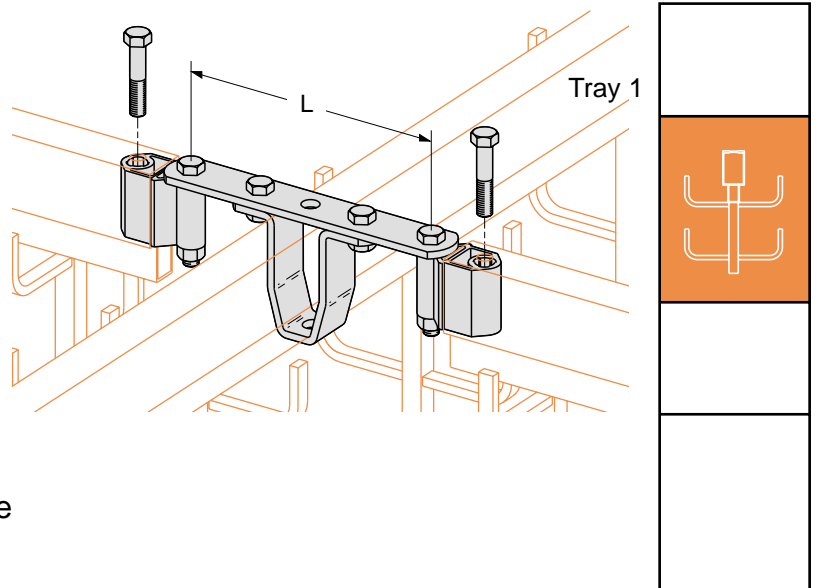

Note: All connectors are aluminum material and sized for 1/2" zinc plated steel hardware, unless otherwise specified.

Vertical Connectors

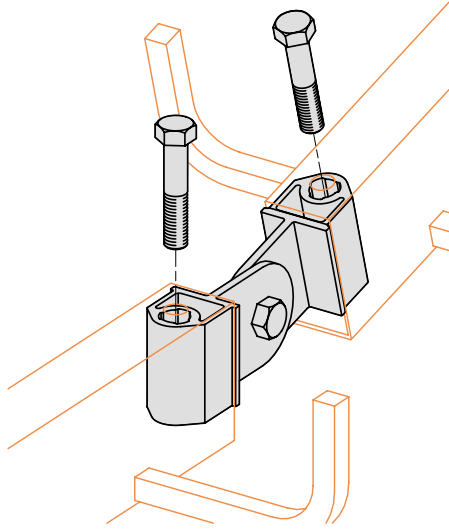
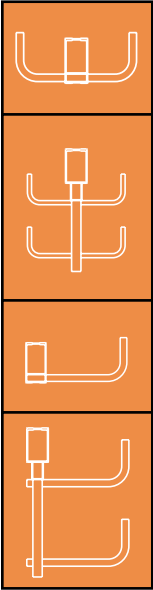

Vertical Adjustable Splice

Cat. No.

CAS-VB

Patented (see page 3)

- Ideal for random angle vertical bends
- Qwik-Bolt® design
- Shipped assembled with required hardware
- UL classified for grounding - 1000 amps

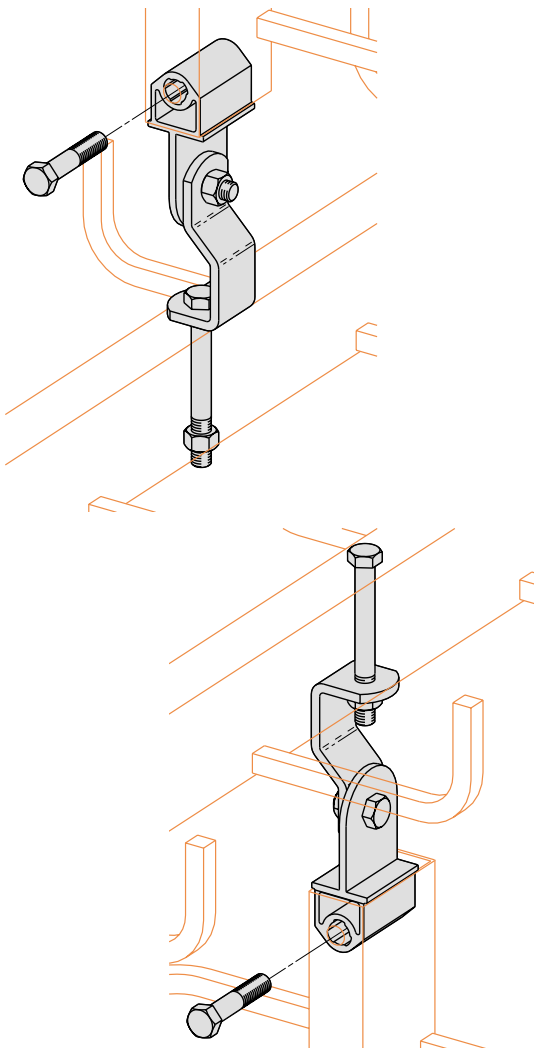

Vertical Coupling

Cat. No.

CAC-VB

Patented (see page 3)

- Use one piece to create vertical tees.
- Use two pieces to create vertical crosses.
- Pivoting connections
- Qwik-Bolt® design
- Shipped assembled with required hardware
- UL classified for grounding - 1000 amps

Multidirectional Connectors

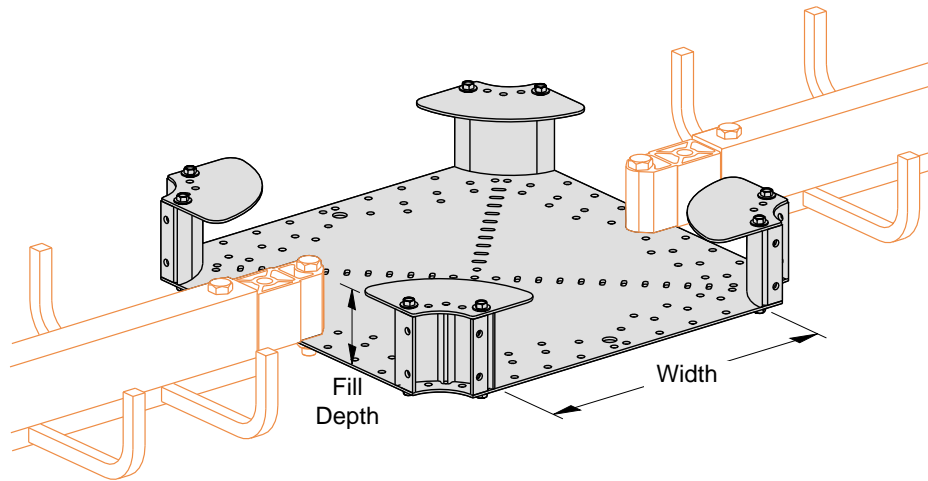

Universal Hub Fittings

Cat. No.	
U 4 A - 12	
Fill	
Depth	Width
2=2"	06 = 6"
3=3"	09 = 9"
4=4"	12 = 12"
6=6"	18 = 18"
	24 = 24"

Patented (see page 3)

- Connects up to 4 trays in random directions
- Provides an area free of center rails for cable transitions
- Ideal for easy system expansion
- Slots provided for cable tie down
- Order one CAT-HBU pivot connector per tray connection (see page 32)
- Positive cable retention for cables routed around corner post
- UL classified for grounding - 1000 amps

Cat. No.
U2A-06
U2A-09
U2A-12
U2A-18
U2A-24
U3A-06
U3A-09
U3A-12
U3A-18
U3A-24
U4A-06
U4A-09
U4A-12
U4A-18
U4A-24
U6A-06
U6A-09
U6A-12
U6A-18
U6A-24

Note: All connectors are aluminum material and sized for 1/2" zinc plated steel hardware, unless otherwise specified.

Multidirectional Connectors

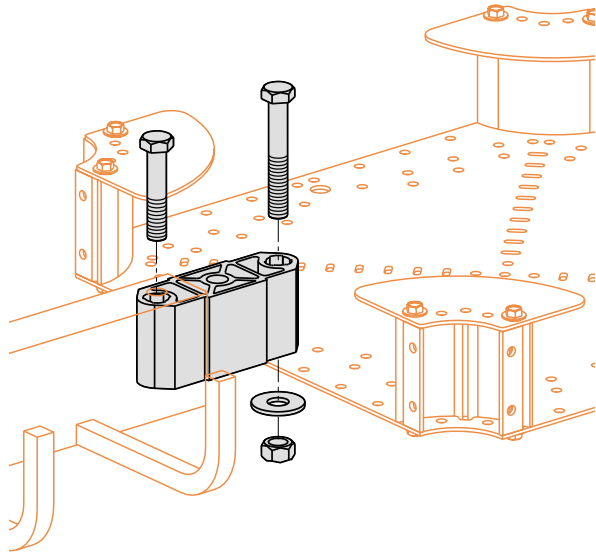
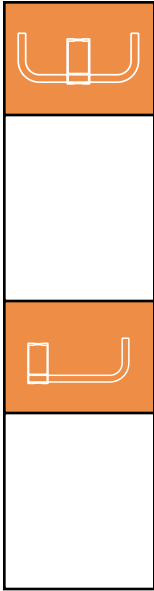

Pivot Connector

Cat. No.	Application
CAC-UFB	Horizontal

Patented (see page 3)

- Qwik-Bolt® design
- Shipped with required hardware
- UL classified for grounding - 1000 amps

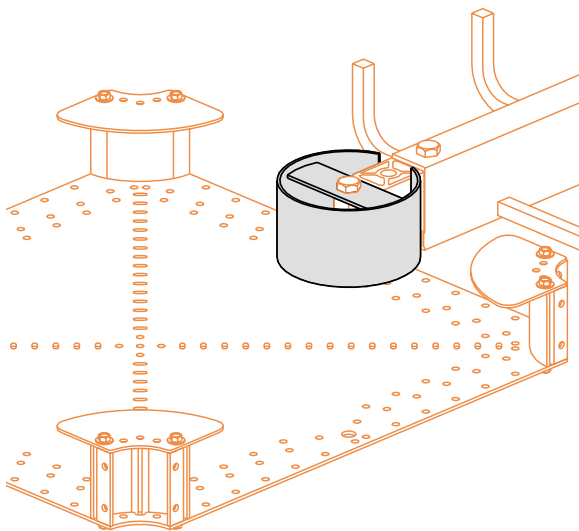
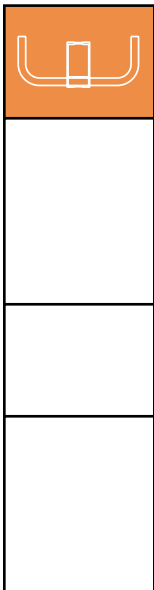

Category 5 Cable Radius Protector

Cat. No.	Tray Depth
CAM-PR253	3
CAM-PR254	4
CAM-PR256	6

- Designed to provide a 2 1/2" cable bend radius
- Mounts directly over the horizontal pivot connector using the existing hardware
- Made from aluminum

Multidirectional Connectors

Typical applications for universal hub fittings:

ELBOW

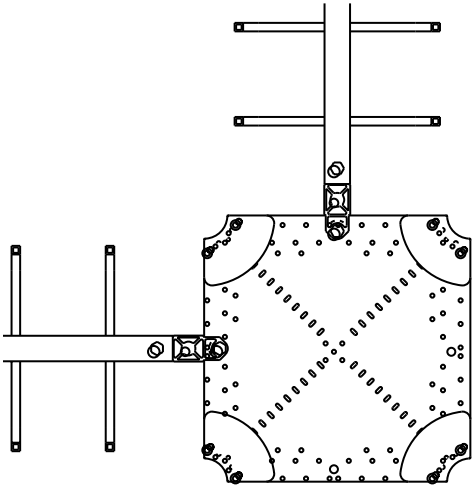

TEE

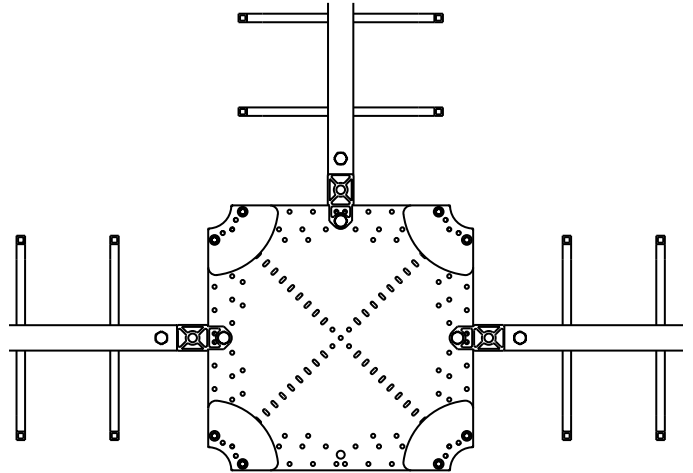

CROSS

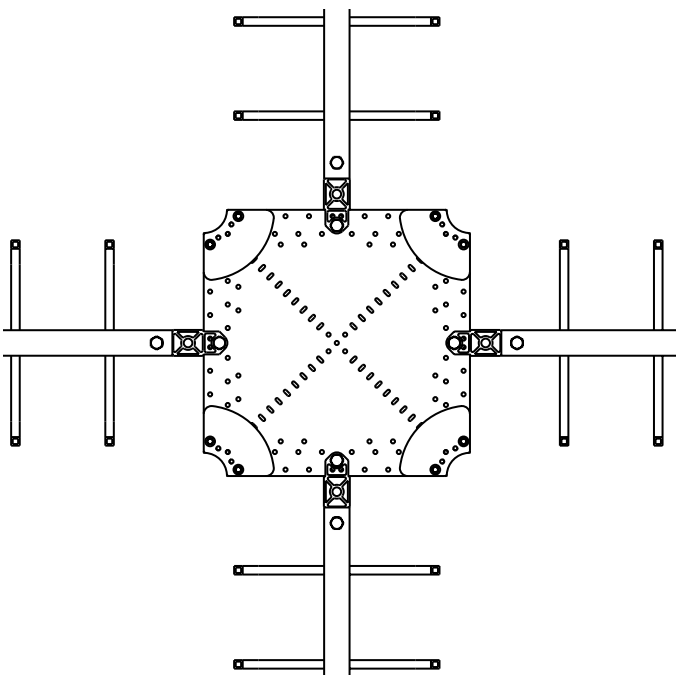

WYE

