

# Cable Tray Selection-Material & Finish

## Standards Available

MATERIAL	MATERIAL SPECIFICATION	ADVANTAGES
Aluminum	6063-T6 (Side rails, Rungs and Splice Plates) 5052-H32 (Trough Bottoms, Covers and Accessories)	<ul style="list-style-type: none"> <li>• Corrosion Resistance</li> <li>• Easy Field Fabrication &amp; Installation</li> <li>• Excellent Strength to Weight Ratio</li> <li>• Excellent Grounding Conductor</li> </ul>
Steel	ASTM A1011 SS Gr. 33 (14 Gauge Plain Steel) ASTM A1008 Gr. 33 Type 2 (16 & 18 Gauge Plain Steel) ASTM A653SS Gr. 33 G90 (Pre-Galvanized)	<ul style="list-style-type: none"> <li>• Electric Shielding</li> <li>• Finish Options</li> <li>• Low Thermal Expansion</li> <li>• Limited Deflection</li> </ul>
Stainless Steel	AISI Type 304 or AISI Type 316 ASTM A240	<ul style="list-style-type: none"> <li>• Superior Corrosion Resistance</li> <li>• Withstands High Temperatures</li> </ul>

### Aluminum

Aluminum cable trays are fabricated from structural grade "copper free" (marine grade) aluminum extrusions. Aluminum's excellent corrosion resistance is due to its ability to form an aluminum oxide film that when scratched or cut reforms the original protective film. Aluminum has excellent resistance to "weathering" in most outdoor applications. Aluminum cable tray has excellent corrosion resistance in many chemical environments and has been used for over thirty years in petro-chemical plants and paper mills along the gulf coast from Texas to Florida. Typically, aluminum cable trays can perform indefinitely, with little or no degradation over time, making it ideal for many chemical and marine environments. The resistance to chemicals, indoor and outdoor, can best be determined by tests conducted by the user with exposure to the specific conditions for which it is intended. For further information, contact B-Line or the Aluminum Association.

Some common chemicals which aluminum resists are shown on pages 12 & 13.

Aluminum Cable Tray

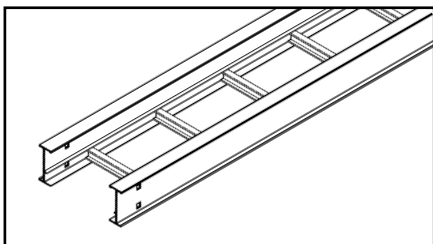

### Steel

Steel cable trays are fabricated from continuous roll-formed structural quality steel. By roll-forming steel, the mechanical properties are increased allowing the use of a lighter gauge steel to carry the required load. This reduces the dead weight that must be carried by the supports and the installers. Using structural quality steel, B-Line assures that the material will meet the minimum yield and tensile strengths of applicable ASTM standards. All cable tray side rails, rungs and splice plates are numbered for material traceability. The corrosion resistance of steel varies widely with coating and alloy.

Steel and Stainless Steel Cable Tray

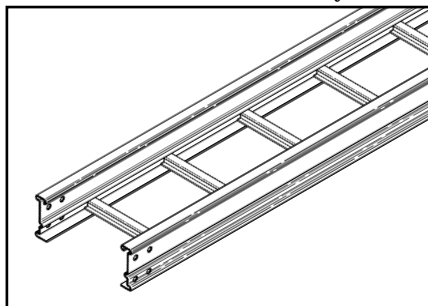

### Stainless Steel

Stainless Steel cable trays are fabricated from continuous roll-formed AISI Type 304 or AISI Type 316/316L stainless steel. Both are non-magnetic and belong to the group called austenitic stainless steels. Like carbon steel, they exhibit increased strength when cold worked by roll-forming or bending.

Several important conditions could make the use of stainless steel imperative. These include long term maintenance costs, corrosion resistance, appearance and locations where product contamination is undesirable. Stainless steel exhibits stable structural properties such as yield strength and high creep strength at elevated temperatures.

B-Line's stainless steel cable trays are welded using stainless steel welding wire to ensure each weldment exhibits the same corrosion resistant characteristic as the base metal. Localized staining in the weld area or heat affected zone may occur in severe environments. Specialized shielding gases and low carbon materials are used to minimize carbon contamination during welding and reduce staining and stress corrosion. Specify passivation after fabrication per ASTM A380 to minimize staining, improve aesthetics and further improve corrosion resistance.

A detailed study of the corrosive environment is recommended when considering a stainless steel design (see pages 12 & 13).

# Cable Tray Selection-Material & Finish

## Standards Available

FINISH	SPECIFICATION	RECOMMENDED USE
<b>Electrogalvanized Zinc</b>	<b>ASTM B633</b> (For Cable Tray Hardware and Accessories, Alum. and Pre-Galv.)	<b>Indoor</b>
<b>Chromium Zinc</b>	<b>ASTM F-1136-88</b> (Hardware for Hot Dip Galvanized Cable Tray)	<b>Indoor/Outdoor</b>
<b>Pre-Galvanized Zinc</b>	<b>ASTM A653SS Gr.33 G90 (CSA Type 2)</b> (Steel Cable Tray and Fittings)	<b>Indoor</b>
<b>Hot Dip Galvanized Zinc After Fabrication</b>	<b>ASTM A123 (CSA Type 1)</b> (Steel Cable Tray and Fittings)	<b>Indoor/Outdoor</b>
<b>Special Paint</b>	<b>Per Customer Specification</b> (Aluminum or Steel Cable Tray & Fittings)	<b>Indoor</b>

### Zinc Coatings

Zinc protects steel in two ways. First it protects the steel as a coating and second as a sacrificial anode to repair bare areas such as cut edges, scratches, and gouges. The corrosion protection of zinc is directly related to its thickness and the environment. This means a .2 mil coating will last twice as long as a .1 mil coating in the same environment.

Galvanizing also protects cut and drilled edges.

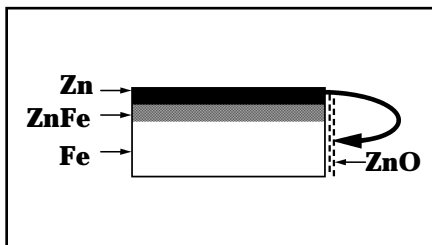

### Electrogalvanized Zinc

Electrogalvanized Zinc (also known as zinc plated or electroplated) is the process by which a coating of zinc is deposited on the steel by electrolysis from a bath of zinc salts. This finish is standard for cable tray hardware and some accessories for aluminum and pre-galvanized systems.

A rating of SC3, B-Line's standard, provides a minimum zinc coating thickness of .5 mils (excluding threaded rod, which is SC1 = .2 mils)

When exposed to air and moisture, zinc forms a tough, adherent, protective film consisting of a mixture of zinc oxides, hydroxides, and carbonates. This film is in itself a barrier coating which slows subsequent corrosive attack on the zinc. This coating is usually recommended for indoor use in relatively dry areas, as it provides ninety-six hours protection in salt spray testing per ASTM B117.

### Chromium/ Zinc

Chromium/ Zinc is a corrosion resistant composition, which was developed to protect fasteners and small bulk items for automotive use. The coating applications have since been extended to larger parts and other markets.

Chromium/Zinc composition is an aqueous coating dispersion containing chromium, proprietary organics, and zinc flake.

This finish provides 1000 hours protection in salt spray testing per ASTM B117, exceeding NEMA VE-1 requirements by 300%.

### Pre-Galvanized Zinc

**(Mill galvanized, hot dip mill galvanized or continuous hot dip galvanized)**

Pre-Galvanized steel is produced by coating coils of sheet steel with zinc by continuously rolling the material through molten zinc at the mills. This is also known as mill galvanized or hot dip mill galvanized. These coils are then slit to size and fabricated by roll forming, shearing, punching, or forming to produce B-Line pre-galvanized cable tray products.

The G90 specification calls for a coating of .90 ounces of zinc per square foot of steel. This results in a coating of .45 ounces per square foot on each side of the sheet. This is important when comparing this finish to hot dip galvanized after fabrication.

During fabrication, cut edges and welded areas are not normally zinc coated; however, the zinc near the uncoated metal becomes a sacrificial anode to protect the bare areas after a short period of time.

To further insure a quality product, B-Line welds all pre-galvanized cable trays with a silicon bronze welding wire

allowing only a small heat affected zone to be exposed. This small area quickly repairs itself by the same process as cut edges.

### Hot Dip Galvanized After Fabrication

**(Hot dip galvanized or batch hot dip galvanized)**

Hot Dip Galvanized After Fabrication cable tray products are fabricated from steel and then completely immersed in a bath of molten zinc. A metallic bond occurs resulting in a zinc coating that completely coats all surfaces, including edges and welds.

Another advantage of this method is coating thickness. Cable trays hot dip galvanized after fabrication have a minimum thickness of 1.50 ounces per square foot on each side, or a total 3.0 ounces per square foot of steel, according to ASTM A123.

The zinc thickness is controlled by the amount of time each part is immersed in the molten zinc bath as well as the speed at which it is removed. The term "double dipping" refers to parts too large to fit into the galvanizing kettle and, therefore, must be dipped one end at a time. It does not refer to extra coating thickness.

The layer of zinc which bonds to steel provides a dual protection against corrosion. It protects first as an overall barrier coating. If this coating happens to be scratched or gouged, zinc's secondary defense is called upon to protect the steel by galvanic action.

Hot dip galvanized after fabrication is recommended for prolonged outdoor exposure and will protect steel for many years in most outdoor environments and in many aggressive industrial environments (see charts on page 10).

# Cable Tray Selection-Material & Finish

## Standards Available

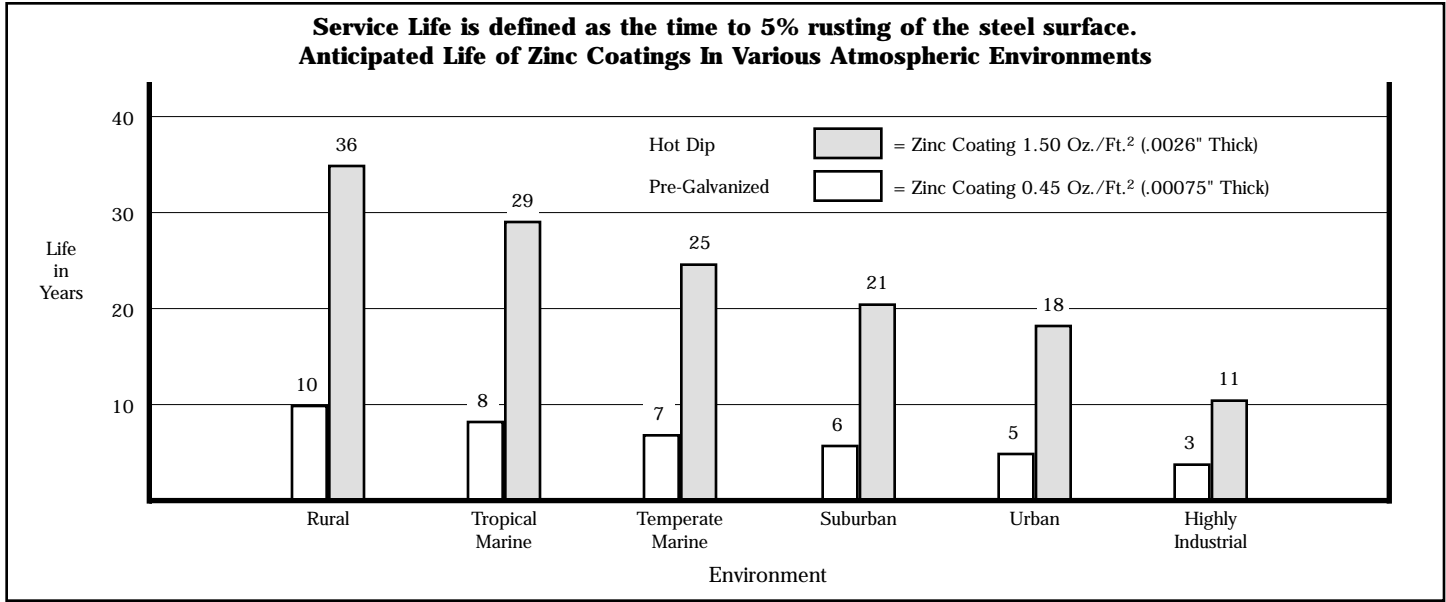

### PVC Coating

PVC coating aluminum or steel cable tray is not recommended and has been removed from B-Line's cable tray line.

The application of a 15 mil PVC coating to aluminum or steel cable tray was a somewhat popular finish option 15 or more years ago. The soft PVC coating must be completely intact for the finish to be effective. In a caustic atmosphere, a pinhole in the coating can render it useless and corrode the cable tray. The shipment of the cable tray consistently damages the coating, as does installation. The splice hardware, splice plates and ground straps require field removal of the coating to ensure connections. PVC coated cable tray drastically increases the product's cost and delivery time.

B-Line recommends using fiberglass - B-Line's catalog CT01FRP, or stainless steel cable tray systems in highly corrosive areas.

### Painting Cable Tray

B-Line offers painted cable tray to any color specified by the customer. It is important to note that there are key advantages and disadvantages to ordering factory painted cable tray. B-Line typically does not recommend factory painted cable tray for most applications.

Painted cable tray is often used in "open ceiling" applications, where all the overhead equipment and structure is painted the same color. In this type of application, additional painting is often necessary in the field, after installation, to ensure all of the supporting components, such as hanger rods, clamps and attaching hardware have been painted uniformly. Pre-painted cable tray interferes with common grounding practices, requiring the paint to be removed at splice locations, and/or the addition of bonding jumpers that were otherwise unnecessary. This additional field modification not only increases the installation cost, but causes potential damage to the special painted finish.

It is typically more cost effective to use an Aluminum or Pre-Galvanized Steel cable tray and paint it after installation, along with the other un-painted building components. Consult painting contractor for proper surface preparation.

### Special Paint

B-Line cable tray and supports can be painted or primed to meet the customers requirements. B-Line has several colors available, consult the factory.

If a non-standard color is required the following information needs to be specified:

1. Type of material preparation (primer, etc.)
2. Type of paint, manufacturer and paint number or type of paint with chip.
3. Dry film thickness.

### Material/Finish Prefix Designation Chart

Catalog Number Prefix	Material to be Furnished
A	Aluminum
P	Pre-Galvanized
G	Hot Dip Galvanized
ZN	Zinc Plated
S	Plain Steel
SS4	Type 304 Stainless Steel
SS6	Type 316 Stainless Steel

# Cable Tray Selection-Material & Finish

## Corrosion

All metal surfaces are affected by corrosion. Depending on the physical properties of the metal and the environment to which it is exposed, chemical or electromechanical corrosion may occur.

### Atmospheric Corrosion

Atmospheric corrosion occurs when metal is exposed to airborne liquids, solids or gases. Some sources of atmospheric corrosion are moisture, salt, dirt and sulphuric acid. This form of corrosion is typically worse outdoors, especially near marine environments.

### Chemical Corrosion

Chemical corrosion takes place when metal comes in direct contact with a corrosive solution. Some factors which affect the severity of chemical corrosion include: chemical concentration level, duration of contact, frequency of washing, and operating temperature.

### Storage Corrosion

Wet storage stain (White rust) is caused by the entrapment of moisture between surfaces of closely packed and poorly ventilated material for an extended period. Wet storage stain is usually superficial, having no affect on the properties of the metal.

Light staining normally disappears with weathering. Medium to heavy buildup should be removed, in order to allow the formation of normal protective film.

Proper handling and storage will help to assure stain-free material. If product arrives wet, it should be unpacked and dried before storage. Dry material should be stored in a well ventilated "low moisture" environment to avoid condensation formation. Outdoor storage is undesirable, and should be avoided whenever possible.

### Galvanic Corrosion

Galvanic corrosion occurs when two or more dissimilar metals are in contacts in the presence of an electrolyte (ie. moisture). An electrolytic cell is created and the metals form an anode or a cathode depending on their relative position on the Galvanic Series Table. The anodic material will be the one to corrode. Whether a material is anodic depends on the relative position of the other material. For example: If zinc and steel are in contact, the zinc acts as the anode and will corrode; the steel acts as the cathode, and will be protected. If steel and copper are in contact, the steel is now the anode and will corrode.

The rate at which galvanic corrosion occurs depends on several factors:

1. The amount and concentration of electrolyte present- An indoor, dry environment will have little or no galvanic corrosion compared to a wet atmosphere.
2. The relative size of the materials- A small amount of anodic material in contact with a large cathodic material will result in greater corrosion. Likewise, a large anode in contact with a small cathode will decrease the rate of attack.
3. The relative position on the Galvanic Series Table- The further apart in the Galvanic Series Table, the greater the potential for corrosion of the anodic material.

## Galvanic Series In Sea Water

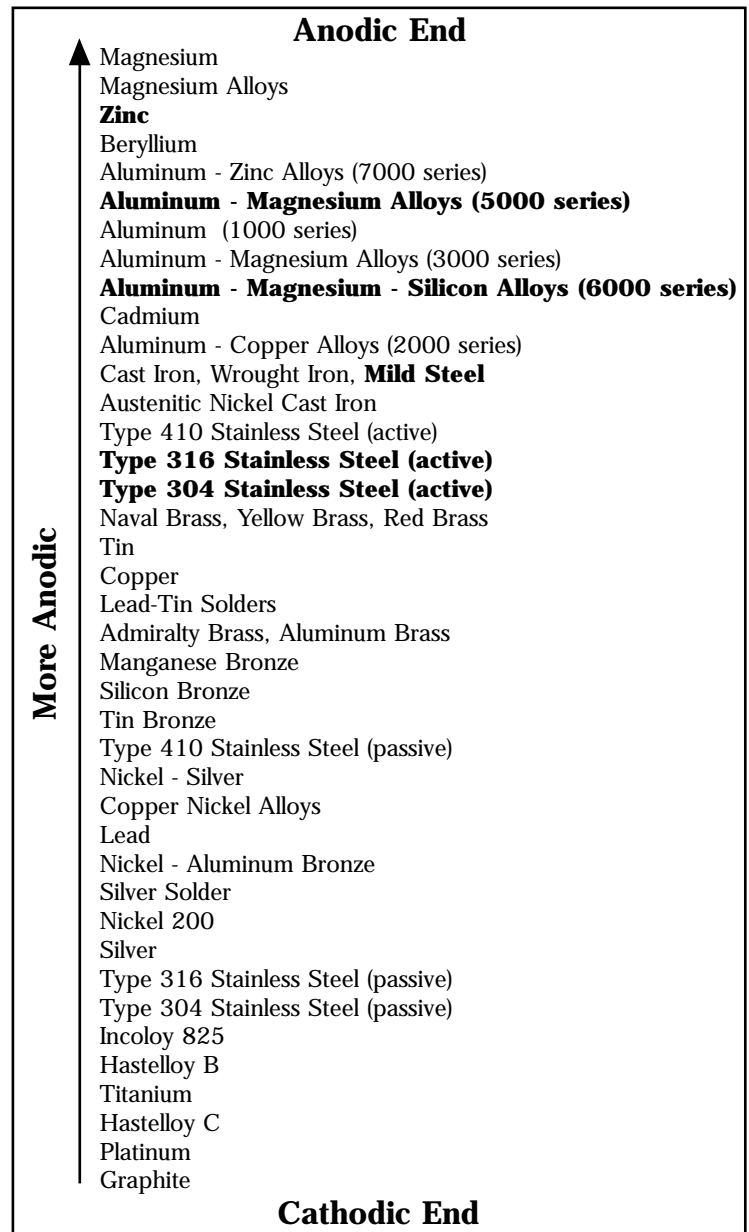

# Cable Tray Selection-Material & Finish

## Corrosion Guide

Chemical	Cable Tray Material								
	Aluminum			Stainless Type 304			Stainless Type 316		
	Cold	Warm	Hot	Cold	Warm	Hot	Cold	Warm	Hot
Acetone	R	R	R	R	R	R	R	R	R
Aluminum Chloride Solution	NR	NR	NR	NR	--	--	F	--	--
Anhydrous Aluminum Chloride	R	R	R	NR	--	--	F	--	--
Aluminum Sulfate	R	R	R	R	R	R	R	R	R
Ammonium Chloride 10%	F	F	NR	R	R	R	R	R	R
Ammonium Hydroxide	F	F	F	R	R	R	R	R	R
Ammonium Phosphate	F	F	NR	R	--	--	R	--	--
Ammonium Sulfate	F	--	--	R	R	R	R	R	R
Ammonium Thiocyanate	R	R	R	R	--	--	R	R	R
Amyl Acetate	R	R	R	R	R	R	R	R	R
Amyl Alcohol	R	R	R	R	--	--	R	R	R
Arsenic Acid	F	F	F	R	R	--	R	R	R
Barium Chloride	F	F	NR	R	R	R	R	R	R
Barium Sulfate	R	R	R	R	R	--	R	R	--
Barium Sulfide	NR	NR	NR	R	R	--	R	R	--
Benzene	R	R	R	R	R	R	R	R	R
Benzoic Acid	F	F	NR	R	R	R	R	R	R
Boric Acid	R	R	F	R	R	R	R	R	R
Bromine Liquid or Vapor	NR	NR	NR	NR	NR	NR	NR	NR	NR
Butyl Acetate	R	R	R	R	--	--	R	R	R
Butyl Alcohol	R	R	R	R	R	R	R	R	R
Butyric Acid	F	F	F	R	R	R	R	R	R
Calcium Chloride 20%	F	F	NR	R	--	--	R	--	--
Calcium Hydroxide	N	--	--	R	R	F	R	R	R
Calcium Hypochlorite 2 - 3%	F	--	--	R	--	--	R	--	--
Calcium Sulfate	R	R	--	R	R	--	R	R	--
Carbon Monoxide Gas	R	R	R	R	R	R	R	R	R
Carbon Tetrachloride	F	F	NR	F	F	F	R	R	R
Chloroform Dry	R	NR	NR	R	R	--	R	R	--
Chloroform Solution	R	NR	NR	--	--	--	--	--	--
Chromic Acid 10% CP	R	R	--	R	R	F	R	R	R
Citric Acid	F	F	F	R	R	NR	R	R	R
Copper Cyanide	NR	NR	NR	R	R	R	R	R	R
Copper Sulfate 5%	NR	NR	NR	R	R	R	R	R	R
Ethyl Alcohol	R	R	R	R	R	R	R	R	R
Ethylene Glycol	R	R	F	R	R	--	R	R	R
Ferric Chloride	NR	NR	NR	NR	NR	NR	NR	NR	NR
Ferrous Sulfate 10%	R	NR	NR	R	R	--	R	R	--
Formaldehyde 37%	R	R	R	R	R	R	R	R	R
Formic Acid 10%	R	R	--	R	R	NR	R	R	R
Gallic Acid 5%	R	R	NR	R	R	R	R	R	R
Hydrochloric Acid 25%	NR	NR	NR	NR	NR	NR	NR	NR	NR
Hydrofluoric Acid 10%	NR	NR	NR	NR	NR	NR	NR	NR	NR
Hydrogen Peroxide 30%	R	R	R	R	R	R	R	R	R
Hydrogen Sulfide Wet	R	--	--	NR	NR	NR	R	R	R

R = Recommended

F = May be used under some conditions

NR = Not Recommended

-- = Information not available

The corrosion data given in this table is for general comparison only. (Reference Corrosion Resistance Tables, Second Edition)

The presence of contaminants in chemical environments can greatly affect the corrosion rate of any material.

B-Line strongly suggests that field service tests or simulated laboratory tests using actual environmental conditions be conducted in order to determine the proper materials and finishes to be selected.

**For questionable environments see B-Line's Fiberglass Cable Tray Catalog (CT01FRP).**

Cold = 50 - 80°F    Warm = 130 - 170°F    Hot = 200 - 212°F

# Cable Tray Selection-Material & Finish

## Corrosion Guide

Chemical	Cable Tray Material								
	Aluminum			Stainless Type 304			Stainless Type 316		
	Cold	Warm	Hot	Cold	Warm	Hot	Cold	Warm	Hot
Lactic Acid 10%	R	F	NR	R	R	F	R	R	R
Lead Acetate 5%	NR	NR	NR	R	R	R	R	R	R
Magnesium Chloride 1%	NR	NR	NR	R	--	F	R	--	R
Magnesium Hydroxide	R	R	R	R	R	--	R	R	--
Magnesium Nitrate 5%	R	--	--	R	R	R	R	R	R
Nickel Chloride	NR	NR	NR	R	--	--	R	--	--
Nitric Acid 15%	NR	NR	NR	R	R	R	R	R	R
Oleic Acid	R	R	F	R	R	F	R	R	R
Oxalic Acid 10%	R	F	NR	NR	NR	NR	R	R	R
Phenol CP	R	R	R	R	R	R	R	R	R
Phosphoric Acid 50%	NR	NR	NR	R	R	R	R	F	NR
Potassium Bromide 100%	R	F	NR	R	R	--	R	R	R
Potassium Carbonate 100%	F	F	--	R	R	R	R	R	R
Potassium Chloride 5%	R	R	R	R	R	R	R	R	R
Potassium Dichromate	R	R	R	R	R	R	R	R	R
Potassium Hydroxide 50%	NR	NR	NR	R	R	R	R	R	R
Potassium Nitrate 50%	R	R	R	R	R	R	R	R	R
Potassium Sulfate 5%	R	R	R	R	R	R	R	R	R
Propyl Alcohol	R	R	R	R	R	R	R	R	R
Sodium Acetate 20%	R	F	F	R	R	R	R	R	R
Sodium Bisulfate 10%	R	F	F	R	R	R	R	R	R
Sodium Borate	R	F	F	R	R	R	R	R	R
Sodium Carbonate 18%	R	F	F	R	R	R	R	R	R
Sodium Chloride 5%	R	NR	NR	R	R	R	R	R	R
Sodium Hydroxide 50%	NR	NR	NR	R	R	R	R	R	R
Sodium Hypochlorite 5%	R	F	F	F	--	--	R	--	--
Sodium Nitrate 100%	R	R	R	R	R	R	R	R	R
Sodium Nitrite 100%	R	R	R	R	R	R	R	R	R
Sodium Sulfate 100%	R	R	F	R	R	R	R	R	R
Sodium Thiosulfate	R	R	R	R	R	R	R	R	R
Sulfur Dioxide (Dry)	R	R	R	R	R	R	R	R	R
Sulfuric Acid 5%	NR	NR	--	F	NR	NR	R	--	--
Sulfuric Acid 10%	NR	NR	NR	NR	NR	NR	NR	NR	NR
Sulfuric Acid 50%	NR	NR	NR	NR	NR	NR	NR	NR	NR
Sulfuric Acid 75 - 98%	NR	NR	NR	NR	NR	NR	NR	NR	NR
Sulfuric Acid 98 - 100%	NR	NR	--	R	--	--	R	R	F
Tannic Acid 10 & 50%	NR	NR	NR	R	R	R	R	R	R
Tartaric Acid 10 & 50%	F	NR	NR	R	R	R	R	R	R
Vinegar	F	F	F	R	R	R	R	R	R
Zinc Chloride 5 & 20%	F	NR	NR	R	F	NR	R	R	R
Zinc Nitrate	F	NR	NR	R	R	R	R	R	R
Zinc Sulfate	F	NR	NR	R	R	R	R	R	R

R = Recommended  
 F = May be used under some conditions  
 NR = Not Recommended  
 -- = Information not available

The corrosion data given in this table is for general comparison only. (Reference Corrosion Resistance Tables, Second Edition)

The presence of contaminants in chemical environments can greatly affect the corrosion rate of any material.

B-Line strongly suggests that field service tests or simulated laboratory tests using actual environmental conditions be conducted in order to determine the proper materials and finishes to be selected.

**For questionable environments see B-Line's Fiberglass Cable Tray Catalog (CT01FRP).**

Cold = 50 - 80°F      Warm = 130 - 170°F      Hot = 200 - 212°F

# Cable Tray Selection-Material & Finish

## Thermal Contraction and Expansion

It is important that thermal contraction and expansion be considered when installing cable tray systems. The length of the straight cable tray runs and the temperature differential govern the number of expansion splice plates required (see Table 1 below).

The cable tray should be anchored at the support nearest to its midpoint between the expansion splice plates and secured by expansion guides at all other support locations (see Figure 1). The cable tray should be permitted longitudinal movement in both directions from that fixed point. When used, covers should be overlapped at expansion splices.

Accurate gap settings at the time of installation are necessary for the proper operation of the expansion splice plates. The following procedure should assist the installer in determining the correct gap: (see Figure 2)

- ① Plot the highest expected metal temperature on the maximum temperature line.
- ② Plot the lowest expected metal temperature on the minimum temperature line.
- ③ Draw a line between the maximum and minimum points.
- ④ Plot the metal temperature at the time of installation to determine the gap setting.

**Figure 1**

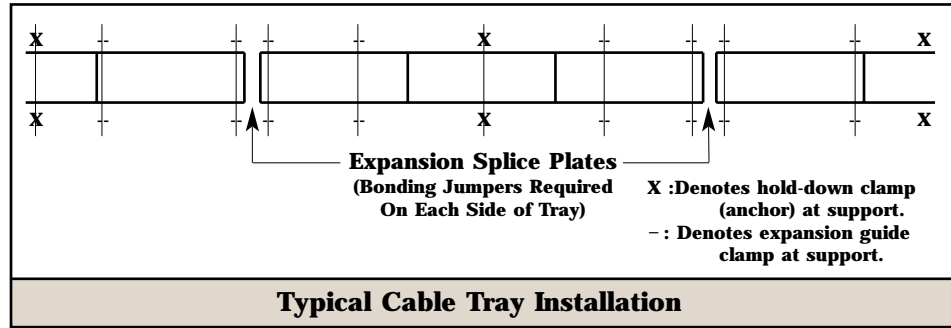

**Figure 2**

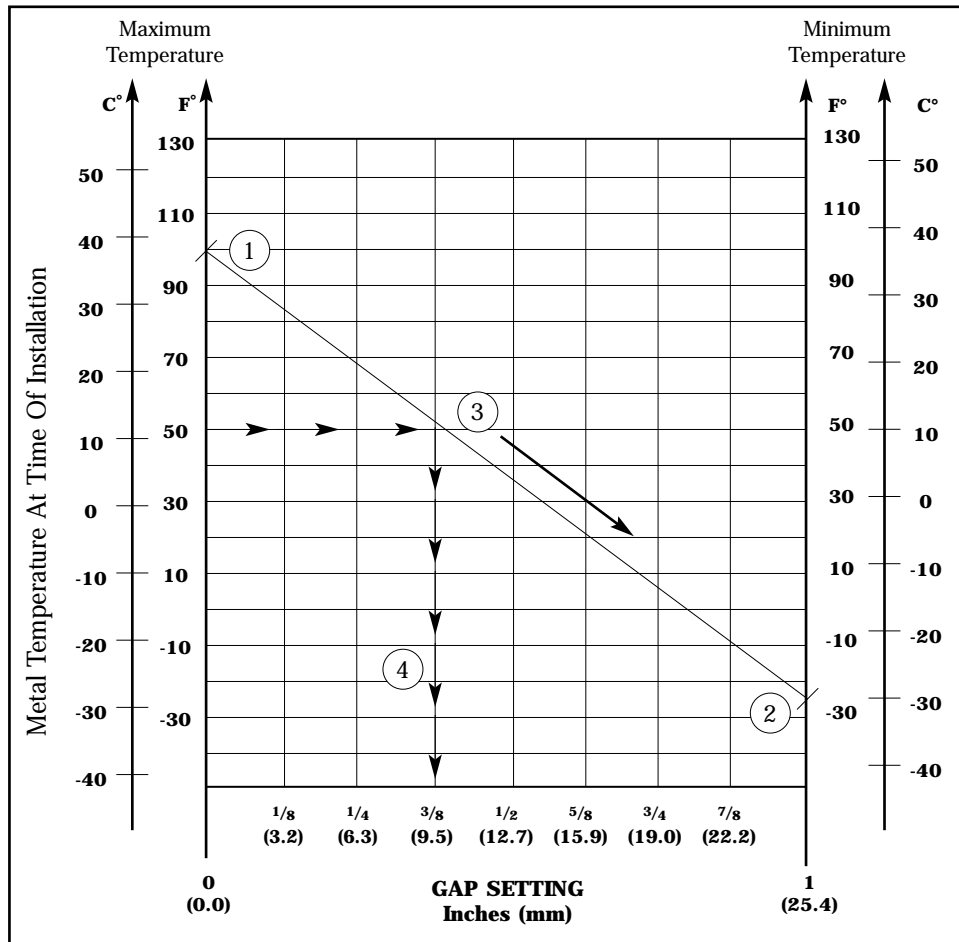

**Table 1**

Maximum Spacing Between Expansion Joints For 1" Movement									
Temperature Differential		Steel		Aluminum		Stainless Steel			
°F	°C	Feet	m	Feet	m	304		316	
						Feet	m	Feet	m
25	13.9	512	156.0	260	79.2	347	105.7	379	115.5
50	27.8	256	78.0	130	39.6	174	53.0	189	57.6
75	41.7	171	52.1	87	26.5	116	35.4	126	38.4
100	55.6	128	39.0	65	19.8	87	26.5	95	29.0
125	69.4	102	31.1	52	15.8	69	21.0	76	23.2
150	83.3	85	25.9	43	13.1	58	17.7	63	19.2
175	97.2	73	22.2	37	11.3	50	15.2	54	16.4

Note: every pair of expansion splice plates requires two bonding jumpers for grounding continuity.

# Cable Tray Selection-Material & Finish

## Installation Considerations

### Weight

The weight of an aluminum cable tray is approximately half that of a comparable steel tray. Some factors to consider include: shipping costs, material, handling, project weight restrictions and the strength of support members.

### Field Modifications

Aluminum cable tray is easier to cut and drill than steel cable tray since it is a “softer” material. Similarly, galvanized steel cable tray is easier to cut and drill than stainless steel cable tray. B-Line aluminum cable tray uses a four bolt splice, resulting in half as much drilling and hardware installation as most steel cable tray, which uses an eight bolt splice. Hot dip galvanized and painted steel cable tray finishes must be repaired when field cutting or drilling. Failure to repair coatings will impair the cable tray’s corrosion resistance.

### Availability

Aluminum, pre-galvanized, stainless steel and fiberglass cable tray can normally be shipped from the factory in a short period of time. Hot dip galvanized and painted cable tray requires an additional coating process, adding several days of preparation before final shipment. Typically, a coated cable tray will be sent to an outside source for coating, requiring additional packing and shipping.

### Electrical Grounding Capacity

The National Electrical Code, Article 392.7 allows cable tray to be used as an equipment grounding conductor. All B-Line standard steel and aluminum cable trays are classified by Underwriter’s Laboratories per NEC Table 392.7 based on their cross-sectional area.

The corresponding cross-sectional area for each side rail design (2 side rails) is listed on a fade resistant UV stabilized label (see Figure 3). This cable tray label is attached to each straight section and fitting that is U.L. classified.

### NEMA Installation Guide

The new NEMA VE-2 is a cable tray installation guideline and is available from NEMA, CTI or B-Line.

**Table 392.7(B)(2)**  
**Metal Area Requirements for Cable Trays**  
**Used as Equipment Grounding Conductors**

Maximum Fuse Ampere Rating, Circuit Breaker Ampere Trip Setting, or Circuit Breaker Protective Relay Ampere Trip Setting for Ground Fault Protection of any Cable Circuit in the Cable Tray System	Minimum Cross-Sectional Area of Metal* In Square Inches	
	Steel Cable Trays	Aluminum Cable Trays
60	0.20	0.20
100	0.40	0.20
200	0.70	0.20
400	1.00	0.40
600	1.50**	0.40
1000	--	0.60
1200	--	1.00
1600	--	1.50
2000	--	2.00**

For SI units: one square inch = 645 square millimeters.

\* Total cross-sectional area of both side rails for ladder or trough-type cable trays; or the minimum cross-sectional area of metal in channel-type cable trays or cable trays of one-piece construction.

\*\* Steel cable trays shall not be used as equipment grounding conductors for circuits with ground-fault protection above 600 amperes. Aluminum cable trays shall not be used as equipment grounding conductors for circuits with ground-fault protection above 2000 amperes.

For larger ampere ratings an additional grounding conductor must be used.

**Figure 3**

WARNING!

**Do Not Use As A Walkway, Ladder,  
Or Support For Personnel.**

**Use Only As A Mechanical Support For Cables, Tubing and Raceways.**

Catalog Number: 24A09-12-144 STR SECTION  
(and description)

Shipping Ticket: 260203 00 001

Mark Number: 78101115400

Purchase Order: D798981

Minimum Area: 1.000 SQ. IN.

Load Class: D1 179 KG/M 3 METER SPAN

REFERENCE FILE # LR360266

This product is classified by Underwriters Laboratories, Inc. as to its suitability as an equipment grounding conductor only. 556E

1 of 1

VENTILATED  
09/05/2002

B-Line

30781011154005

# Cable Tray Selection-Strength

## Cable Data Multiconductor Cable Type TC, 600V with XHHW Conductors, Copper

The cable load is simply the total weight of all the cables to be placed in the tray. This load should be expressed in lbs/ft. The data on this page provides average weights for common cable sizes.

Size	3 conductors with ground			4 conductors with ground		
	Diameter in.	Area in. <sup>2</sup>	Weight lbs/ft	Diameter in.	Area in. <sup>2</sup>	Weight lbs/ft
8	0.66	0.34	0.33	0.72	0.41	0.42
6	0.74	0.43	0.45	0.81	0.52	0.58
4	0.88	0.61	0.66	0.96	0.72	0.84
2	1.00	0.79	0.96	1.10	0.95	1.20
1	1.13	1.00	1.17	1.25	1.23	1.55
1/0	1.22	1.17	1.43	1.35	1.43	1.84
2/0	1.31	1.35	1.72	1.45	1.65	2.20
3/0	1.42	1.58	2.14	1.58	1.96	2.80
4/0	1.55		2.64	1.77		3.46
250	1.76		3.18	1.93		4.04
350	1.98		4.29	2.18		5.48
500	2.26		5.94	2.50		7.64
750	2.71		9.01	3.12		11.40
1000	3.10		11.70			

## Multiconductor Cable Type MC, 600V with XHHW Conductors, Copper

Size	3 conductors with ground						4 conductors with ground					
	Diameter (in.)		Area (in. <sup>2</sup> )		Weight (lbs/ft)		Diameter (in.)		Area (in. <sup>2</sup> )		Weight (lbs/ft)	
	Without Jacket	With Jacket	Without Jacket	With Jacket	Alum. Armor	Steel Armor	Without Jacket	With Jacket	Without Jacket	With Jacket	Alum. Armor	Steel Armor
8	0.70	0.80	0.38	0.50	0.41	0.57	0.76	0.86	0.45	0.58	0.51	0.68
6	0.78	0.88	0.48	0.61	0.55	0.74	0.85	0.95	0.57	0.71	0.69	0.87
4	0.89	0.99	0.62	0.77	0.74	0.95	0.97	1.07	0.74	0.90	0.93	1.15
2	1.01	1.12	0.80	0.99	1.08	1.32	1.10	1.22	0.95	1.17	1.29	1.56
1	1.16	1.27	1.06	1.27	1.38	1.63	1.25	1.36	1.23	1.45	1.61	1.91
1/0	1.23	1.34	1.19	1.41	1.56	1.86	1.35	1.46	1.43	1.67	1.94	2.27
2/0	1.32	1.43	1.37	1.61	1.85	2.20	1.46	1.56	1.67	1.91	2.36	2.72
3/0	1.46	1.57	1.67	1.94	2.35	2.67	1.58	1.71	1.96	2.30	2.94	3.33
4/0	1.56	1.68			2.82	3.21	1.75	1.88			3.64	3.97
250	1.74	1.86			3.31	3.94	1.92	2.04			4.21	4.64
350	1.96	2.10			4.48	4.97	2.16	2.30			5.71	6.12
500	2.24	2.37			6.08	6.58	2.47	2.63			7.91	8.39
750	2.68	2.84			8.96	9.70	3.03	3.22			11.48	12.17

## Single Conductor Cable 600V

Size	XHHW			THHN, THWN			TW, THW			USE, RHH, RHW		
	Diameter in.	Area in. <sup>2</sup>	Weight lbs/ft	Diameter in.	Area in. <sup>2</sup>	Weight lbs/ft	Diameter in.	Area in. <sup>2</sup>	Weight lbs/ft	Diameter in.	Area in. <sup>2</sup>	Weight lbs/ft
1/0	0.48		0.37	0.50		0.37	0.53		0.39	0.53		0.39
2/0	0.52		0.46	0.54		0.46	0.57		0.48	0.57		0.49
3/0	0.58		0.57	0.60		0.57	0.62		0.60	0.63		0.60
4/0	0.63		0.71	0.66		0.71	0.68		0.74	0.68		0.75
250	0.70	0.38	0.85	0.72	0.41	0.85	0.75	0.44	0.88	0.76	0.45	0.89
300	0.75	0.44	1.02	0.77	0.47	1.02	0.81	0.52	1.04	0.81	0.52	1.05
350	0.80	0.50	1.17	0.83	0.54	1.17	0.86	0.58	1.21	0.86	0.58	1.22
400	0.85	0.57	1.33	0.87	0.59	1.33	0.90	0.64	1.37	0.91	0.65	1.38
500	0.93	0.68	1.64	0.96	0.72	1.64	0.98	0.75	1.69	0.99	0.77	1.70
600	1.04	0.85	2.03	1.06	0.88	2.01	1.09	0.93	2.03	1.10	0.95	2.07
750	1.14	1.02	2.24	1.17	1.08	2.48	1.19	1.11	2.51	1.20	1.13	2.55
1000	1.29		2.52	1.32		3.30	1.34		3.31	1.35		3.33

# Cable Tray Selection-Strength

## Environmental Loads

### Wind Loads

Wind loads need to be determined for all outdoor cable tray installations. Most outdoor cable trays are ladder type trays, therefore the most severe loading to be considered is impact pressure normal to the cable tray side rails (see detail 1).

Detail 1



The impact pressure corresponding to several wind velocities are given below in Table 1.

**Table 1**  
**Impact Pressures**

V(mph)	P(lbs/ft <sup>2</sup> )	V(mph)	P(lbs/ft <sup>2</sup> )
15	0.58	85	18.5
20	1.02	90	20.7
25	1.60	95	23.1
30	2.30	100	25.6
35	3.13	105	28.2
40	4.09	110	30.9
45	5.18	115	33.8
50	6.39	120	36.8
55	7.73	125	40.0
60	9.21	130	43.3
65	10.80	135	46.6
70	12.50	140	50.1
75	14.40	145	53.8
80	16.40	150	57.6

V= Wind Velocity  
P= Impact Pressure

Note: These values are for an air density of 0.07651 lbs/ft<sup>3</sup> corresponding to a temperature of 60° F and barometric pressure of 14.7 lbs/in<sup>2</sup>.

### Example Calculation:

Side load for 6" side rail with 100 mph wind

$$\frac{25.6 \times 6}{12} = 12.8 \text{ lbs/ft}$$

When covers are installed on outdoor cable trays, another factor to be considered is the aerodynamic effect which can produce a lift strong enough to separate a cover from a tray. Wind moving across a covered tray (see detail 2) creates a positive pressure inside the tray and a negative pressure above the cover. This pressure difference can lift the cover off the tray.

Detail 2

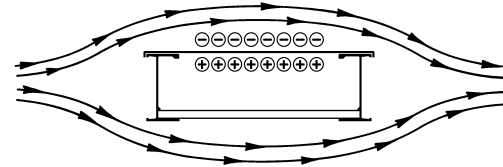

B-Line recommends the use of heavy duty wrap-around cover clamps when covered trays are installed in an area where strong winds occur.

### Special Notice:

Covers on wide cable tray and/or cable tray installed at elevations high off the ground may require additional heavy duty clamps or thicker cover material.

# Cable Tray Selection-Strength

## Environmental Loads

### Ice Loads

Glaze ice is the most commonly seen form of ice build-up. It is the result of rain or drizzle freezing on impact with an exposed object. Generally, only the top surface (or the cover) and the windward side of a cable tray system is significantly coated with ice. The maximum design load to be added due to ice should be calculated as follows:

$$L_i = \left( \frac{W \times T_i}{144} \right) \times D_i \text{ where;}$$

$L_i$  = Ice Load (lbs/linear foot)

$W$  = Cable Tray Width (inches)

$T_i$  = Maximum Ice Thickness (inches)

$D_i$  = Ice Density = 57 lbs/ft<sup>3</sup>

the maximum ice thickness will vary depending on location. A thickness of 1/2" can be used as a conservative standard.

### Example Calculation:

Ice Loads for 24" wide tray with 1/2" thick ice;

$$\frac{24 \times .5}{144} \times 57 = 4.75 \text{ lbs/ft}$$

### Snow Loads

Snow is measured by density and thickness. The density of snow varies almost as much as its thickness. The additional design load from snowfall should be determined using the building codes which apply for each installation.

### Seismic Loads

A great deal of seismic testing and evaluation of cable tray systems, and their supports, has been performed. The conclusions reached from these evaluations is that cable tray is stronger laterally than vertically, since it acts as a truss in the lateral direction. Other factors that contribute to the stability of cable tray are the energy dissipating motion of the cables within the tray, and the high degree of ductility of the cable tray and the support material.

These factors, working in conjunction with a properly designed cable tray system, should afford reasonable assurance to withstand even strong motion earthquakes.

When seismic bracing is required for a cable tray system, it should be applied to the supports and not the cable tray itself. B-Line's "Seismic Restraints" brochure provides OSHPD approved methods of bracing cable tray supports using standard B-Line products. Contact B-Line to receive a copy of this brochure.

## Concentrated Loads

A concentrated static load represents a static weight applied at a single point between the side rails. Tap boxes, conduit attachments and long cable drops are just some of the many types of concentrated loads. When so specified, these concentrated static loads may be converted to an equivalent, uniform load ( $W_e$ ) by using the following formula:

$$W_e = \frac{2 \times (\text{concentrated Static Load})}{\text{span length}}$$

B-Line's cable tray side rails, rungs and bottoms will withstand a 200 lb. static load without collapse (series 14 excluded)\*. However, it should be noted that per NEMA Standard Publication VE1 cable tray is designed as a support for power or control cables, or both, and is not intended or designed to be a walkway for personnel. Each section of B-Line Cable Tray has a label stating the following message:

**Warning! Not to be used as a walkway, ladder or support for personnel. To be used only as a mechanical support for cables and raceway.**

## Support Span

The strength of a cable tray is largely determined by the strength of its side rails. The strength of a cable tray side rail is proportionate to the distance between the supports on which it is installed, commonly referred to as the “support span”. Therefore, the strength of a cable tray system can be altered by changing the support span. However, there is a limit to how much the strength of a cable tray system can be increased by reducing the support span, because the strength of the cable tray bottom members could become the determining factor of strength.

Once the load requirement of a cable tray system has been established, the following factors should be considered:

1. Sometimes the location of existing structural beams will dictate the cable tray support span. This is typical with outdoor installations where adding intermediate supports could be financially prohibitive. For this situation the appropriate cable tray must be selected to accommodate the existing span.

2. When cable tray supports are randomly located, the added cost of a higher strength cable tray system should be compared to the cost of additional supports. Typically, adding supports is more costly than installing a stronger series of cable tray. The stronger cable tray series (e.g. from NEMA 20B to NEMA 20C) will increase the price of the cable tray system minimally, possibly less than \$1/ft., with little or no additional labor cost for installation. Alternately, one extra support

may cost \$80.00 (material and labor) for a simple trapeze. Future cable additions or the capability of supporting equipment, raceways for example, also favor stronger cable tray systems. *In summary, upgrading to a stronger cable tray series is typically more cost-effective than using the recommended additional supports for a lighter duty cable tray series.*

3. The support span lengths should be equal to or less than unspliced straight section lengths, to ensure that no more than one splice is placed between supports.

# Cable Tray Selection-Strength

## Deflection

Deflection in a cable tray system is primarily an aesthetic consideration. When a cable tray system is installed in a prominent location, a maximum simple beam deflection of 1/200 of support span can be used as a guideline to minimize visual deflection.

It is important at this point to mention that there are two typical beam configurations, simple beam and continuous beam, and to clarify the difference.

A good example of a simple beam is a single straight section of cable tray supported, but not fastened at either end. When the tray is loaded the cable tray is allowed to flex. Simple beam analysis is used almost universally for beam comparisons even though it is seldom practical in the field installations. The three most prominent reasons for using a simple beam analysis are: calculations are simplified; it represents the worst case loading; and testing is simple and reliable. The published load data in the B-Line cable tray catalog is based on the simple beam analysis per NEMA & CSA Standards.

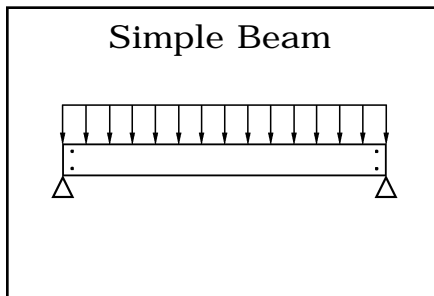

Continuous beam is the beam configuration most commonly used in cable tray installations. An example of this configuration is where cable trays are installed

across several supports to form a number of spans. The continuous beam possesses traits of both the simple and fixed beams. When equal loads are applied to all spans simultaneously, the counterbalancing effect of the loads on both sides of a support restricts the movement of the cable tray at the support. The effect is similar to that of a fixed beam. The end spans behave substantially like simple beams. When cable trays of identical design are compared, the continuous beam installation will typically have approximately half the deflection of a simple beam of the same span. Therefore simple beam data should be used only as a general comparison. The following factors

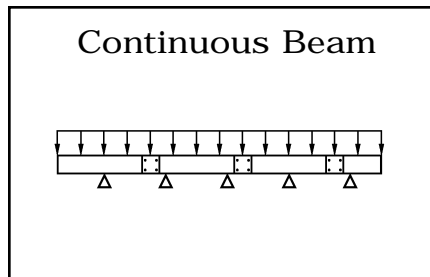

should be considered when addressing cable tray deflection:

1. Economic consideration must be considered when addressing cable deflection criteria.
2. Deflection in a cable tray system can be reduced by decreasing the support span, or by using a taller or stronger cable tray.
3. When comparing cable trays of equivalent strength, a steel cable tray will typically exhibit less deflection than an aluminum cable tray since the modulus of elasticity of steel is nearly three times that of aluminum.

4. The location of splices in a continuous span will affect the deflection of the cable tray system. The splices should be located at points of minimum stress whenever practical. NEMA Standards VE-1 limits the use of splice plates as follows:

Unspliced straight sections should be used on all simple spans and on end spans of continuous span runs. Straight section lengths should be equal to or greater than the span length to ensure not more than one splice between supports.

See the figures below for splicing configuration samples.

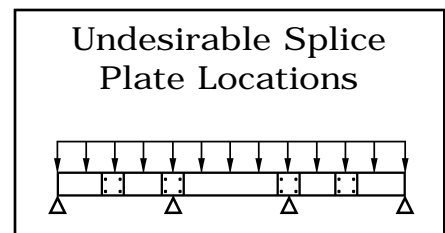
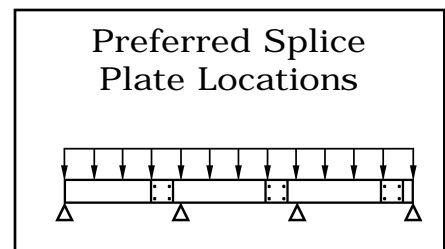
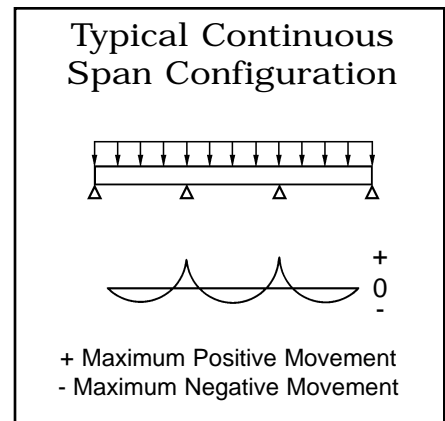

# Cable Tray Selection-Strength

## Load Capacity

Calculate each anticipated load factor, then add them to obtain a total load. (Example: Working Load = Cable + Concentrated + Wind + Snow + Ice Loads). The Working Load should be used, along with the maximum support spacing, to select a span/load class designation from Table 2. Table 2 contains the most common load/span class designations per the US and Canadian metallic cable tray standard, CSA, C22.2 No. 126.1-98 First Addition, NEMA VE 1-1998.

**Table 2 - Most Common Load/Span Class Designations**

Load Class		Class Designations for lengths of									
		ft 8	m (2.4)	ft 10	m (3.0)	ft 12	m (3.7)	ft 16	m (4.9)	ft 20	m (6.0)
25	37	--		A		--		--		--	
45	67	--		--		--		--		D	
50	74	8A		--		12A		16A		20A	
65	97	--		C		--		--		--	
75	112	8B		--		12B		16B		E or 20B	
100	149	8C		--		12C		16C		20C	
120	179	--		D		--		--		--	
200	299	--		E		--		--		--	

Note: 8A/B/C, 12A/B/C, 16A/B/C, and 20A/B/C are the traditional NEMA designations. A, C, D, and E are the conventional CSA designations. Other load rating and support spacing are acceptable per manufacturer testing.

**Table 3 - B-Line Cable Tray Load Classes**











Aluminum Copper free				Steel HDGAF/Pre-Galvanized			
Series	Load Depth	NEMA Class	CSA Class	Series	Load Depth	NEMA Class	CSA Class
14A	3	8B		148*	3	12A	C <sub>1</sub> (3m)
M14A	3	12A	C <sub>1</sub> (3m)	248*	3	12C	D <sub>1</sub> (3m)
H14AR	3	12B	D <sub>1</sub> (3m)	346*	3	20A	D <sub>1</sub> (6m)
24A	3	12C	D <sub>1</sub> (3m)	444*	3	20B	E (3m)
M24A	3	20A	D <sub>1</sub> (6m), E (3m)	156*	4	12B	C <sub>1</sub> (3m)
34A	3	20B	E (6m)	258*	4	12C	D <sub>1</sub> (3m)
H15AR	4	12C	D <sub>1</sub> (3m)	356*	4	16C	D <sub>1</sub> (6m)
25A	4	16B	D <sub>1</sub> (6m)	358*	4	20A	D <sub>1</sub> (6m)
35A	4	20B	E (3m)	454*	4	20C	E (6m)
H16AR	5	12C	D <sub>1</sub> (3m)	166*	5	12B	C <sub>1</sub> (3m)
26A	5	20A	D <sub>1</sub> (6m)	268*	5	12C	D <sub>1</sub> (3m)
36A	5	20B	E (6m)	368†	5	20A	D <sub>1</sub> (6m)
46A	5	20C	CSA Tested	366*	5	20B	E (6m)
M46A	5	116# @ 20'		464*†	5	119# @ 20'	E (6m)
H46A	5	167# @ 20'	CSA Tested	176*	6	12B	
H17AR	6	12B	D <sub>1</sub> (3m)	378*	6	20A	D <sub>1</sub> (3m)
37A	6	20B		476*	6	20B	D <sub>1</sub> (6m)
47A	6	20C		574*	6	117# @ 20'	E (6m)
H47A	6	149# @ 20'		* G denotes CSA Type 1 (HDGAF) P denotes CSA Type 2 (Mill-Galvanized) † SS4 (Type 304 Stainless) or SS6 (Type 316 Stainless)			
57A	6	75# @ 30'	CSA Tested				
S8A	7	173# @ 30'	CSA Tested				

H14AR, H15AR, H16AR, H17AR see Redi-Rail Catalog.

# Cable Tray Selection-Strength

## Load Capacity

### Ladder Type Rungs

Rung Type	Design Factors	Material Type	Single Rung Uniform Load Capacity (in Lbs.) with safety factor of 1.5						
			Tray Width						
			6	9	12	18	24	30	36
	$I_x = .0361 \text{ in.}^4$ $S_x = .0707 \text{ in.}^3$	Aluminum				766	575		
	$I_x = .0432 \text{ in.}^4$ $S_x = .0877 \text{ in.}^3$	Aluminum						594	495
	$I_x = .0249 \text{ in.}^4$ $S_x = .0528 \text{ in.}^3$	Steel	2912	1941	1456	971	728		
	$I_x = .0312 \text{ in.}^4$ $S_x = .0661 \text{ in.}^3$	Steel						749	624
	$I_x = .0450 \text{ in.}^4$ $S_x = .0787 \text{ in.}^3$	Aluminum Strut Rung	3328	2219	1664	1109	832	666	555
	$I_x = .0554 \text{ in.}^4$ $S_x = .0968 \text{ in.}^3$	Steel Strut Rung	6400	4267	3200	2133	1600	1280	1067
	$I_x = .0129 \text{ in.}^4$ $S_x = .0314 \text{ in.}^3$	Aluminum Series 1	1312	875	656	437	328	262	219
	$I_x = .0039 \text{ in.}^4$ $S_x = .0134 \text{ in.}^3$	Steel Series 1	981	654	491	327	245		
	$I_x = .0047 \text{ in.}^4$ $S_x = .0164 \text{ in.}^3$	Steel Series 1						230	192
	$I_x = .0497 \text{ in.}^4$ $S_x = .0828 \text{ in.}^3$	Aluminum Marine Rung	4096	2731	2048	1365	1024	819	683
	$I_x = .0456 \text{ in.}^4$ $S_x = .0797 \text{ in.}^3$	Steel Marine Rung	3648	2432	1824	1216	912	730	608

### Corrugated Bottoms (Ventilated and Solid)

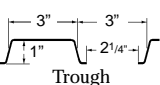
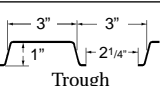
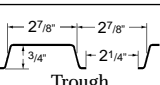
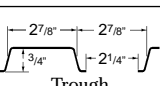
Bottom Type	Design Factors	Material Type	Single Rung Load Capacity (in Lbs.) with safety factor of 1.5						
			Tray Width						
			6	9	12	18	24	30	36
	$I_x = .0455 \text{ in.}^4$ $S_x = .0898 \text{ in.}^3$	Aluminum	3141	2029	1491	970	726	660	594
	$I_x = .0348 \text{ in.}^4$ $S_x = .0667 \text{ in.}^3$	Steel	2973	1946	1445	955	711	650	590
	$I_x = .0243 \text{ in.}^4$ $S_x = .0677 \text{ in.}^3$	Series One Aluminum	2448	1632	1224	816	612		
	$I_x = .0185 \text{ in.}^4$ $S_x = .0503 \text{ in.}^3$	Series 148 Steel	2645	1763	1323	881	661		

# Cable Tray Selection-Width and Available Loading Depth

## Allowable Cable Fill

*For allowable cable types see the Appendix page A-9.*

The following guidelines are based on the 2002 National Electrical Code, Article 392.

## I) Number of Multiconductor Cables rated 2000 volts or less in the Cable Tray

### (1) 4/0 or Larger Cables

The ladder cable tray must have an inside available width equal to or greater than the sum of the diameters (Sd) of the cables, which must be installed in a single layer. When using solid bottom cable tray, the sum of the cable diameters is not to exceed 90% of the available cable tray width.

**Example:** Cable Tray width is obtained as follows:

List Cable Sizes	(D) List Cable Outside Diameter	(N) List Number of Cables	Multiply (D) x (N) = Subtotal of the Sum of the Cable Diameters
3/C - #500 kcmil	2.26 inches	1	2.26 inches
3/C - #250 kcmil	1.76 inches	2	3.52 inches
3/C - #4/0 AWG	1.55 inches	4	6.20 inches

The sum of the diameters (Sd) of all cables = 2.26 + 3.52 + 6.20 = 11.98 inches; therefore a cable tray with an available width of at least 12 inches is required.

### (2) Cables Smaller Than 4/0

The total sum of the cross-sectional areas of all the cables to be installed in the cable tray must be equal to or less than the allowable cable area for the tray width, as indicated in Table 3. When using solid bottom cable tray, the allowable cable area is reduced by 22%.

# Cable Tray Selection-Width and Available Loading Depth

## Allowable Cable Fill

Table 3

Inside Width of Cable Tray inches	Allowable Cable Area square inches
6	7.0
9	10.5
12	14.0
18	21.0
24	28.0

**Example:** The cable tray width is obtained as follows:

List Cable Sizes	(A) List Cable Cross Sectional Areas	(N) List Number of Cables	Multiply (A) x (N) = Total of the Cross-Sectional Area for each Size
3/C - #12 AWG	0.167 sq. in.	10	1.67 sq. in.
4/C - #12 AWG	0.190 sq. in.	8	1.52 sq. in.
3/C - # 6 AWG	0.430 sq. in.	6	2.58 sq. in.
3/C - # 2 AWG	0.800 sq. in.	9	7.20 sq. in.

The sum of the total areas is  $1.67 + 1.52 + 2.58 + 7.20 = 12.97$  inches. Using Table 3, a 12-inch wide tray with an allowable cable area of 14 sq. inches should be used.

Note: Increasing the cable tray loading depth does not permit an increase in allowable cable area for power and lighting cables. The maximum allowable cable area for all cable tray with a 3 inch or greater loading depth is limited to the allowable cable area for a 3 inch loading depth.

### (3) 4/0 or Larger Cables Installed with Cables Smaller than 4/0

The ladder cable tray needs to be divided into two zones (a barrier or divider is not required but one can be used if desired) so that the No. 4/0 and larger cables have a dedicated zone, as they are to be placed in a single layer.

A direct method to determine the correct cable tray width is to figure the cable tray widths required for each of the cable combinations per steps (2) & (3). Then add the widths in order to select the proper cable tray width.

# Cable Tray Selection-Width and Available Loading Depth

## Allowable Cable Fill

**Example:** The cable tray width is obtained as follows:

**Part A-** Width required for #4/0 AWG and larger multiconductor cables

List Cable Size	(D) List Cable Outside Diameter	(N) List Number of Cables	Multiply (D) x (N) = Subtotal of the Sum of the Cable Diameters (Sd)
3/C - #500 kcmil	2.26 inches	1	2.26 inches
3/C - #4/0 AGW	1.55 inches	2	3.10 inches

Cable tray width (inches) required for large cables = 2.26 + 3.10 = 5.36 inches.

**Part B-** Width required for multiconductor cables smaller than #4/0 AWG

List Cable Sizes	(A) List Cable Cross Sectional Areas	(N) List Number of Cables	Multiply (A) x (N) = Total of the Cross-Sectional Area for each Size
3/C - #12 AWG	0.167 sq. in.	10	1.67 sq. in.
3/C - #6 AWG	0.430 sq. in.	8	3.44 sq. in.
3/C - #2 AWG	0.800 sq. in.	2	1.60 sq. in.

The sum of the total areas (inches) = 1.67 + 3.44 + 1.60 = 6.71 sq. inches.  
From Table 3, the cable tray width required for small cables is 6 inches.

The total cable tray width (inches) = 5.36 + 6.00 = 11.36 inches. A 12-inch wide cable tray is required.

### (4) Multiconductor Control and/or Signal Cables Only

A ladder cable tray containing only control and/or signal cables, may have 50% of its total available cable area filled with cable. When using solid bottom cable tray pans, the allowable cable area is reduced from 50% to 40%.

Example: Cable tray width is obtained as follows:

2/C- #16 AWG instrumentation cable cross sectional area = 0.04 sq. in.

Total cross sectional area for 300 Cables = 12.00 sq. in.

Minimum available cable area needed = 12.00 x 2 = 24.00 sq. in.; therefore the cable tray width required for 4 inch available loading depth tray = 24.00/4 = 6 inches.

# Cable Tray Selection-<sup>Width and Available Loading Depth</sup>

## Allowable Cable Fill

### II) Number of Single Conductor Cables Rated 2000 Volts or Less in the Cable Tray

All single conductor cables to be installed in the cable tray must be 1/0 or larger, and are not to be installed with continuous bottom pans.

#### (1) 1000 KCMIL or Larger Cables

The sum of the diameters (Sd) for all single conductor cables to be installed shall not exceed the cable tray width. See Table 5.

#### (2) 250 KCMIL to 1000 KCMIL Cables

The total sum of the cross-sectional areas of all the single conductor cables to be installed in the cable tray must be equal to or less than the allowable cable area for the tray width, as indicated in Table 4. (Reference Table 6)

Table 4

Inside Width of Cable Tray inches	Allowable Cable Area square inches
6	6.50
9	9.50
12	13.00
18	19.50
24	26.00
30	32.50
36	39.00

#### (3) 1000 KCMIL or Larger Cables Installed with Cables Smaller Than 1000 KCMIL

The total sum of the cross-sectional areas of all the single conductor cables to be installed in the cable tray must be equal to or less than the allowable cable area for the tray width, as indicated in Table 5.

Table 5

Inside Width of Cable Tray inches	Allowable Cable Area square inches
6	6.50 - (1.1 Sd)
9	9.50 - (1.1 Sd)
12	13.00 - (1.1 Sd)
18	19.50 - (1.1 Sd)
24	26.00 - (1.1 Sd)
30	32.50 - (1.1 Sd)
36	39.00 - (1.1 Sd)

# Cable Tray Selection-<sup>Width and Available Loading Depth</sup>

## Allowable Cable Fill

### (4) Single Conductor Cables 1/0 through 4/0

These single conductors must be installed in a single layer. See Table 6.

Note: It is the opinion of some that this practice may cause problems with unbalanced voltages. To avoid these potential problems, the individual conductors for this type of cable tray wiring system should be bundled with ties. The bundle should contain all of the three-phase conductors for the circuit, plus the neutral if used. The single conductor cables bundle should be firmly tied to the cable tray assembly at least every 6 feet.

**Table 6**  
**Number of 600 Volt Single Conductor Cables**  
**That May Be Installed in Ladder Cable Tray**

Single Conductor Size	Outside Diameter in.	Area sq. in.	Cable Tray Width				
			6 in.	9 in.	12 in.	18 in.	24 in.
1/0	0.58	-	10	15	20	31	41
2/0	0.62	-	9	14	19	29	38
3/0	0.68	-	8	13	17	26	35
4/0	0.73	-	8	12	16	24	32
250 Kcmil	0.84	.55	11	18	24	35	47
350 Kcmil	0.94	.69	9	14	19	28	38
500 Kcmil	1.07	.90	7	11	14	22	29
750 Kcmil	1.28	1.29	5	8	10	15	20
1000 Kcmil	1.45	-	4	6	8	12	16

Cable diameters used are those for Oknite-Okolon 600 volt single conductor power cables.

### III) Number of Type MV and MC Cables Rated 2001 Volts or Over in the Cable Tray

The sum of the diameters (Sd) of all cables, rated 2001 volts or over, is not to exceed the cable tray width.

# Cable Tray Selection-Width and Available Loading Depth

Sizing Cable Tray Per 2002 NEC 392

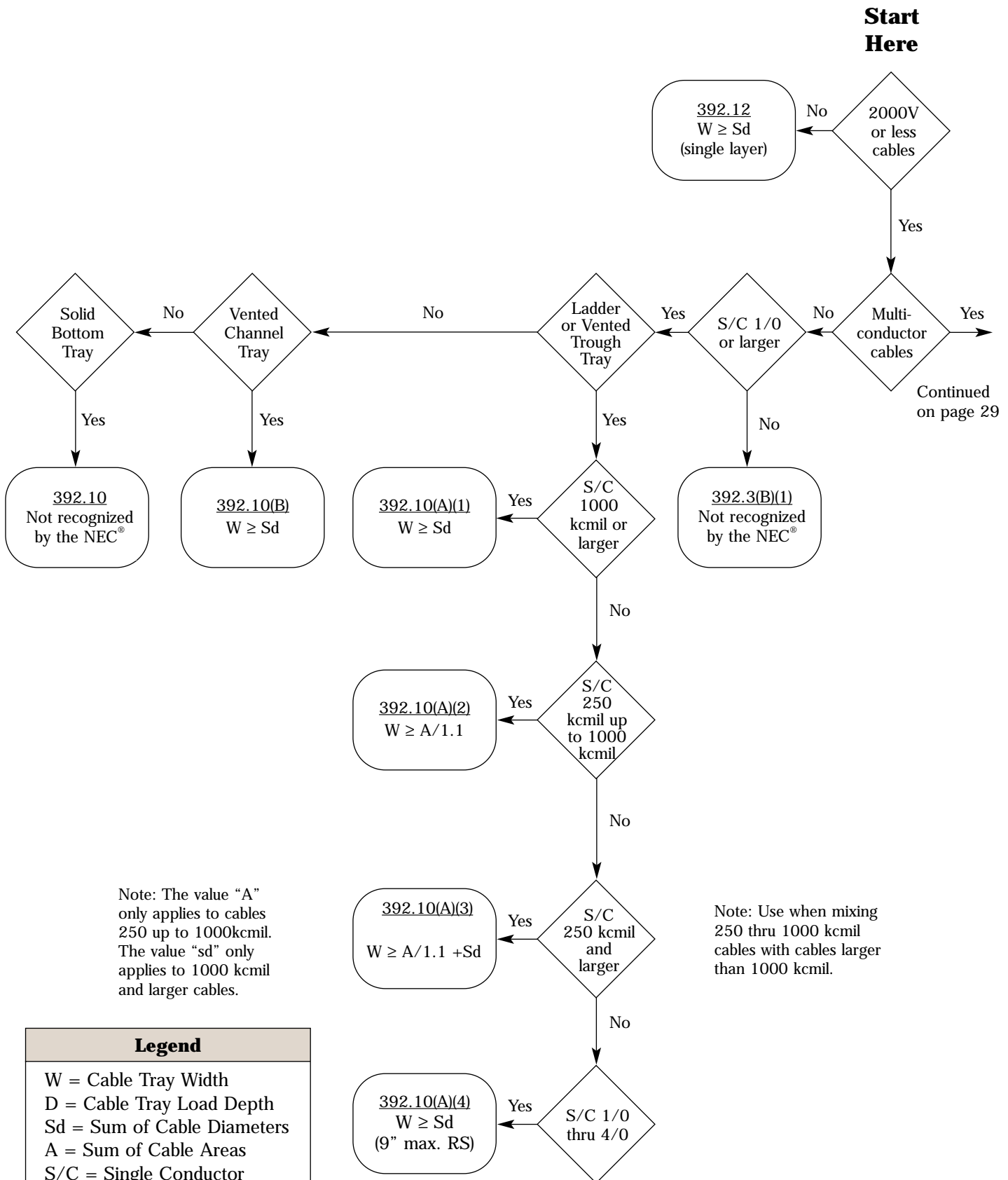

Legend
W = Cable Tray Width
D = Cable Tray Load Depth
Sd = Sum of Cable Diameters
A = Sum of Cable Areas
S/C = Single Conductor
M/C = Multiconductor Cables
RS = Ladder Rung Spacing

# Cable Tray Selection - Width and Available Loading Depth

Note: See appendix on page A-18 for additional information regarding cable ampacity and hazardous (classified) location requirements which might effect the cable tray sizing flow chart.

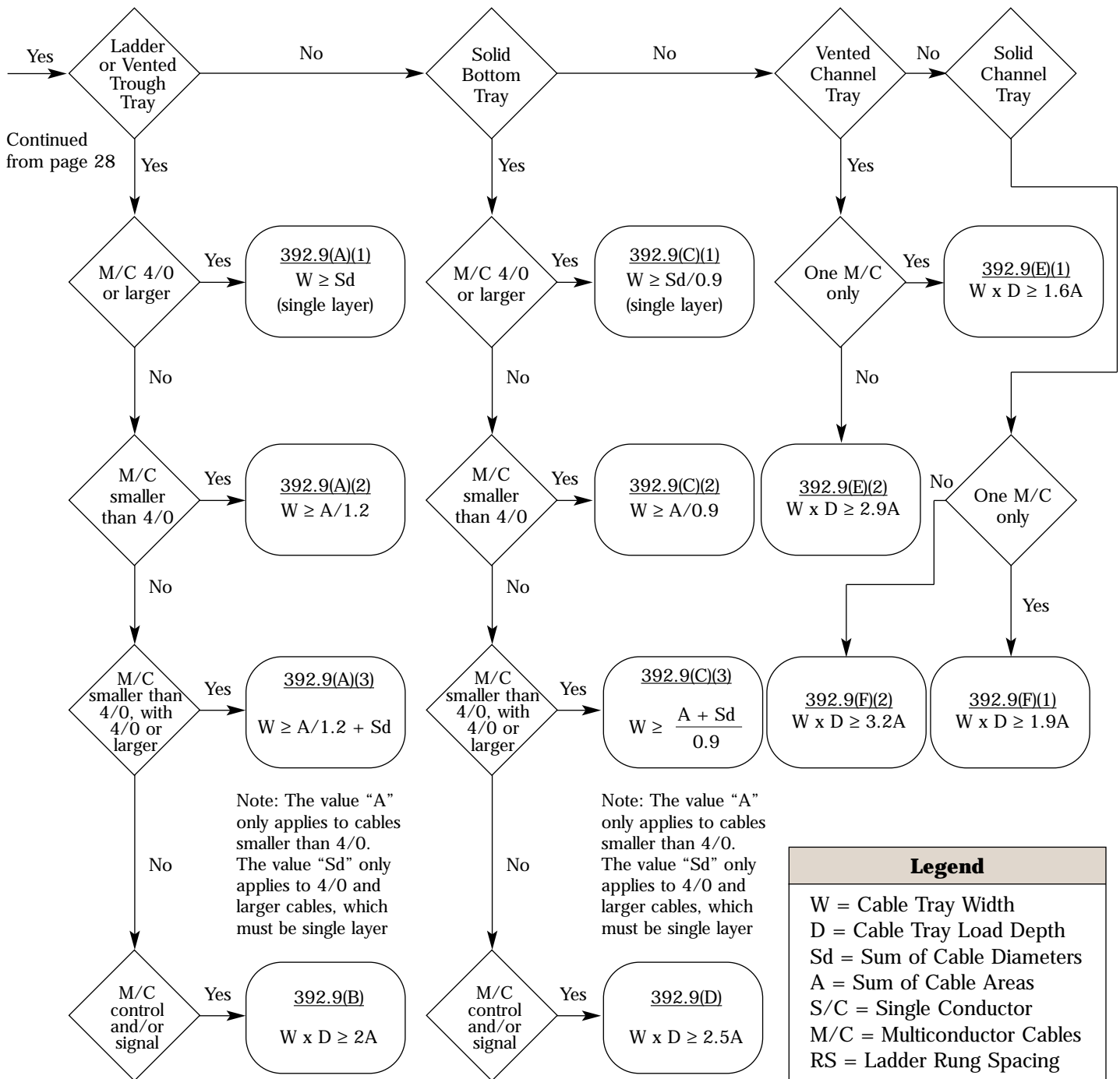

# Cable Tray Selection-Width and Available Loading Depth

## Barrier Requirements

Barrier strips are used to separate cable systems, such as when cables above and below 600 volts per NEC 392.6(F) are installed in the same cable tray. However, when MC type cables rated over 600 volts are installed in the same cable tray with cables rated 600 volts or less, no barriers are required. The barriers should be made of the same material type as the cable tray.

When ordering the barrier, the height must match the *loading depth* of the cable tray into which it is being installed.

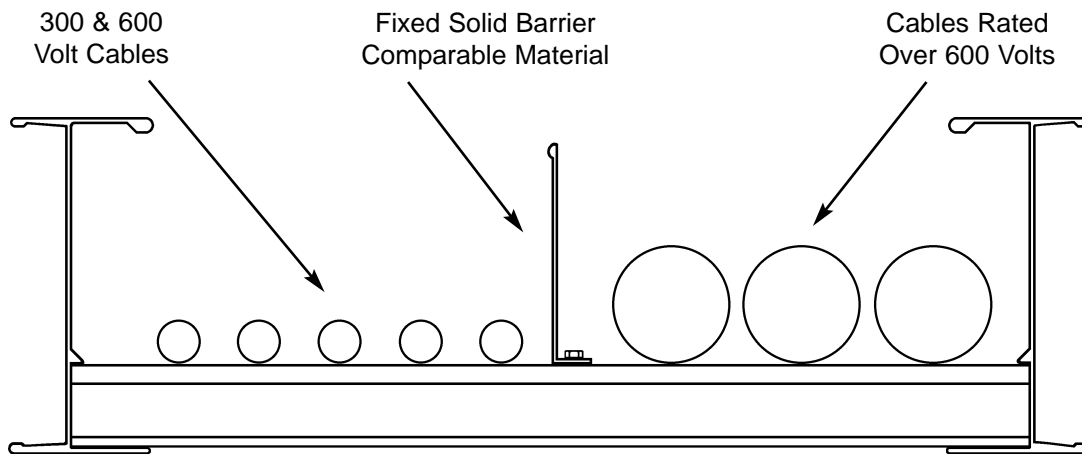

## Future Expansion Requirements

One of the many features of cable tray is the ease of adding cables to an existing system. Future expansion should always be considered when selecting a cable tray, and allowance should be made for additional *fill area* and *load capacity*. A minimum of 50% expansion allowance is recommended.

## Space Limitations

Any obstacles which could interfere with a cable tray installation should be considered when selecting a cable tray width and height. Adequate clearances should be allowed for installation of supports and for cable accessibility. Note: The overall cable tray dimensions typically exceed the nominal tray width and loading depth.

# Cable Tray Selection-Length

## Lengths Available

The current Cable Tray Standard, NEMA VE-1 and C22.2 No. 126.1-98, lists typical lengths as 3000 mm (10 ft), 3660 mm (12 ft), 6000 mm (20 ft), and 7320 mm (24 ft). It is impractical to manufacture either lighter systems in the longer lengths or heavier systems in the shorter lengths. For that reason, B-Line has introduced a primary and secondary length for each system. These straight section lengths were selected to direct the user to lengths that best suit support span demands and practical loading requirements. The primary length is the one that is the most appropriate for the strength of the system and that will provide the fastest service levels. The secondary lengths will be made available to service additional requirements. Special lengths are available with extended lead times.

---

---

## Support Span

The support span on which a cable tray is installed should not exceed the length of the unspliced straight section. Thus installations with support spans greater than 12 feet should use 240" (20 feet) or 288" (24 feet) cable tray lengths.

## Space Limitations

Consideration should be given to the space available for moving the cable tray from the delivery truck to its final installation location. Obviously, shorter cable tray allows for more maneuverability in tight spaces.

## Installation

Shorter cable tray lengths are typically easier to maneuver on the job site during installation. Two people may be needed to manipulate longer cable tray sections, while shorter sections might be handled by one person. Although longer cable tray lengths are more difficult to maneuver, they can reduce installation time due to the fact that there are fewer splice connections. This trade-off should be evaluated for each set of job site restrictions.

# Cable Tray Selection <sup>Loading</sup> Possibilities

## Power Application:

Power application can create the heaviest loading. The heaviest cable combination found was for large diameter cables (i.e. steel armor, 600V, 4 conductor 750 kcmil). The cables weigh less than 3.8 lbs. per inch-width of cable tray. As power cables are installed in a single layer, the width of the cable affects the possible loading.

36" Wide	30" Wide	24" Wide	18" Wide	12" Wide	9" Wide	6" Wide
140 lbs/ft	115 lbs/ft	90 lbs/ft	70 lbs/ft	45 lbs/ft	35 lbs/ft	23 lbs/ft

## Data/Communication Cabling:

Low voltage cables can be stacked as there is no heat generation problems. The NEC employs a calculation of the total cross sectional area of the cables not exceeding 50% of the fill area of the cable tray. As the cable fill area of the cable tray system affects the possible loading, both the loading depth and width of the systems must be considered. For this example 4UTP category 5 cable (O.D. = .21, .026 lbs./ft.) were used.

### Calculated Cable Weight in Lbs/Ft

	36" Wide	30" Wide	24" Wide	18" Wide	12" Wide	9" Wide	6" Wide
6" Fill	81	64	52	41	27	20	14
5" Fill	68	53	43	34	23	17	12
4" Fill	54	43	35	27	18	13	9
3" Fill	41	32	26	21	14	10	7
2" Fill	27	21	17	14	9	7	5



The picture shows a 12" cable tray with a 3" load depth. The tray contains 520 4 UTP Category 5 cables with a .21" diameter.

The National Electrical Code allows for 50% fill of ventilated and ladder cable tray for control or signal wiring (Article 392.9(B)). ANSI/EIA/TIA 569-A Section 4.5\* also requires that the fill ratio of cable tray is not to exceed 50%.

Calculation Example: Tray Area = 12 in. x 3 in. = 36 sq. in.  
 50% Fill = 36 sq. in. x .5 = 18 sq. in.  
 Cable Area = (.21 in.)<sup>2</sup> x 3.14/4 = .0346 sq. in.  
 Number of Cables = 18 sq. in. / .0346 sq. in. = 520 cables

\*Section 4.5 is currently under review.

## Other Factors To Consider

- **Support Span** - The distance between the supports affects the loading capabilities exponentially. To calculate loading values not cataloged use:

$$W_1 L_1^2 = W_2 L_2^2$$

$W_1$  - tested loading

$L_1$  - span in feet, a tested span

$W_2$  - loading in question

$L_2$  - known span for new loading

- **Other Loads** - Ice, wind, snow for outdoor systems see page 17 and 18 for information.

A 200 lb. concentrated load for industrial systems. The affect of a concentrated load can be calculated as follows

$$\frac{2 \times (\text{concentrated static load})}{\text{span in feet}}$$

When considering concentrated loads the rung strength should be considered.

- **Length Of The Straight Sections:**

The VE-2, Cable Tray Installation Guide, states that the support span shall not be greater than the straight section length. If a 20C system is manufactured in 12 foot sections the greatest span for supports would be 12 feet. This dramatically affects the loading of the system.

$$W_1 L_1^2 = W_2 L_2^2$$

$$100 (20^2) = W_2 (12^2)$$

$$40,000 = 144 W_2$$

$$W_2 = 277 \text{ lbs. per foot}$$

# Cable Tray Selection-*Bottom Type*

## Type of Cable

According to NEC Article 392, multiconductor tray cable may be installed in any standard cable tray bottom type. Single conductor tray cable may be installed only in ladder or ventilated bottom cable trays (not solid bottom). Solid bottom cable trays are not allowed to be installed in Class II, Division 2 locations (2002 NEC Section 502.4(B)). In general, small, highly flexible cables should be installed in solid bottom, vented bottom or 6" rung spacing ladder type cable trays. Sensitive cables (e.g. fiberoptic) are typically installed in flat, solid bottom cable trays, instead of corrugated trough bottoms. Larger, less flexible cables are typically installed in ladder type cable trays having 9" or 12" rung spacing. Ladder type cable trays having 18" rung spacing should be used for large, stiff cables to reduce cost and facilitate cable drop-outs.

## Cost vs Strength

Often more than one bottom type is acceptable. In this case the economic difference should be considered. Ladder cable trays have a lower cost than either solid or ventilated bottom configurations. Typically, the cost of ladder type cable tray decreases as rung spacing increases. However, the effect of rung spacing on load capacity for ladder type cable trays with 18" rung spacing should be evaluated, since NEMA published load capacities are based on 12" rung spacing. Rung spacing can affect individual rung and side rail loading as well as system load capacity. Rung loads applied during cable instal-

lation should also be considered. (See page 22 for B-Line rung load capacities)

## Cable Exposure

Tray cables are manufactured to withstand the environment without additional protection, favoring the use of the ladder type cable tray. Some areas may benefit from the limited exposure of solid or vented bottom cable tray. Solid Bottom metal cable tray with solid metal covers can be utilized in other spaces used for environmental air to support non plenum rated tray cables (2002 NEC<sup>®</sup> 300.22(C)(1))

## Cable Attachment

The major advantage of ladder type cable tray is the freedom of entry and exit of the cables. Another advantage of ladder type cable tray is the ability to secure cables in the cable tray. With standard rungs the cables may be attached with either cable ties or cable clamps. The ladder type cable tray is also available with special purpose, slotted marine or strut rungs to facilitate banding or clamping cables. Cable attachment is particularly important on vertical runs or when the tray is installed on its side. Ladder rung spacing should be chosen to provide adequate cable attachment points while allowing the cables to exit the system.

# Cable Tray Selection-Fitting Radius

## Cable Flexibility

The proper bend radius for cable tray fittings is usually determined by the bend radius and stiffness of the tray cables to be installed. Typically, the tray cable manufacturer will recommend a minimum bend allowance for each cable. The fitting radius should be equal to or larger than the minimum bend radius of the largest cable which may ever be installed in the system. When several cables are to be installed in the same cable tray, a larger bend radius may be desirable to ease cable installation.

## Space Limitations

The overall dimensions for a cable tray fitting will increase as the bend radius increases. Size and cost make the smallest acceptable fitting radius most desirable. When large radius fittings are required, the system layout must be designed to allow adequate space.