

Heavy Duty Aluminum *Framing System*

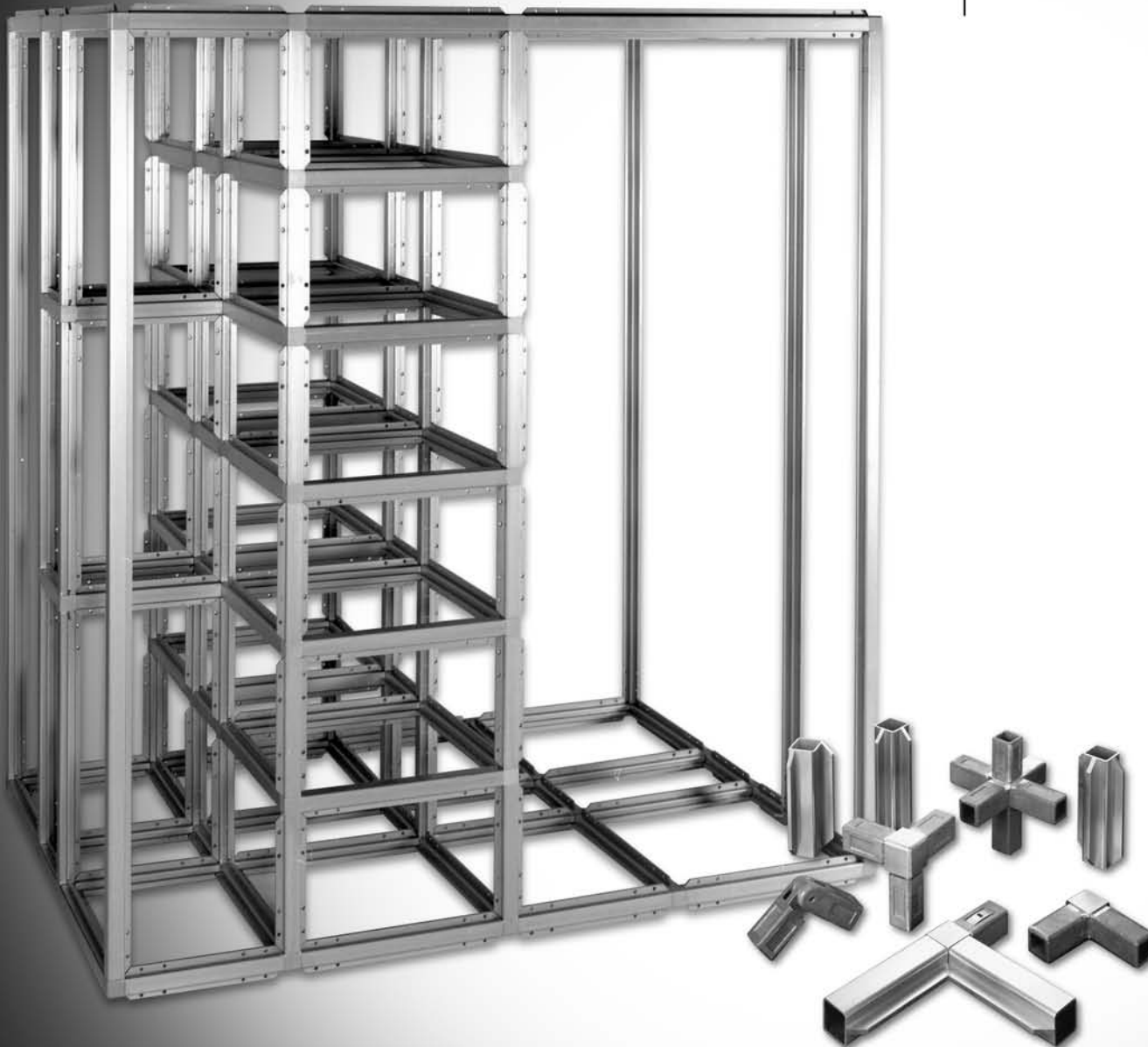

A Simple, Strong Solution for Many Enclosure Problems

Our heavy-duty aluminum structural framing system (SFS) is a simple method of designing and building frames and enclosures to special size and high strength requirements. This unique IMS Engineered Products system provides a selection of 14 aluminum extrusions (1.50" OD) and 8 types of corner castings (0.125" wall thickness) commonly utilized in all sectors of Industry.

The flanges in the extrusions accommodate .125" flat panels or .625" formed panels. The system accepts locking clips (when design will be permanent) or non-locking clips for prototypes or planned disassembly. IMS Engineered Products' standard line of components can be integrated into the framing system to speed and support the development process. Structures created with the IMS Engineered Products structural framing system provide exceptionally high strength and load bearing capabilities; its corner locking methods actually surpass the strength of welded joints. When reinforced with bolt-on gussets, SFS assemblies can meet MIL-STD-167-1 shock and vibration requirements. In many cases, these aluminum structures can be interfaced with steel console assemblies.

IMS Engineered Products's structural framing system can meet complex design requirements for military and commercial applications, and has proven its mettle in such high profile work as the NASA Space Program. Other examples of its use include heavy electrical generator housings, major process control installations, communications systems, and weather-sealed outdoor enclosures. From laboratory layouts to the most intricate console assemblies, the IMS Engineered Products aluminum structural framing system is a reliable choice.

Ordering Information

IMS Engineered Products heavy-duty structural framing system can be ordered in the following ways to meet your current and future requirements:

- Completely assembled and shipped ready-to-load
- In pre-configured or cut-to-size kits; your assembly required
- As bulk material—castings and extrusions you can stock, cut, and modify yourself, based on per project requirements.

Material Specifications

Castings: 356-T6 aluminum per ASTM B108

Extrusions: 6061-T6 aluminum per ASTM B221

Maximum extrusion length is 20'. Extrusions are supplied without mounting holes. Extrusions will be pre-cut to length and mitered to 90° angles at no additional cost. Castings are furnished with locking clips for assembly to extrusions. Special services available include: machining, hardware installation, marking, and packaging.



Custom Application Shown

Castings

ALC-1 Three Corner Casting • **ALC-2** Four Ear Corner, Joining or Foot Casting • **ALC-3** 0° to 120° Hinged Casting • **ALC-4** Three Ear Corner Casting • **ALC-5** Two Ear Corner Casting • **ALC-6** Five Ear Corner Casting • **ALC-7** Four Ear (cross) Joining Casting "X" • **ALC-8** Six Ear Joining Casting

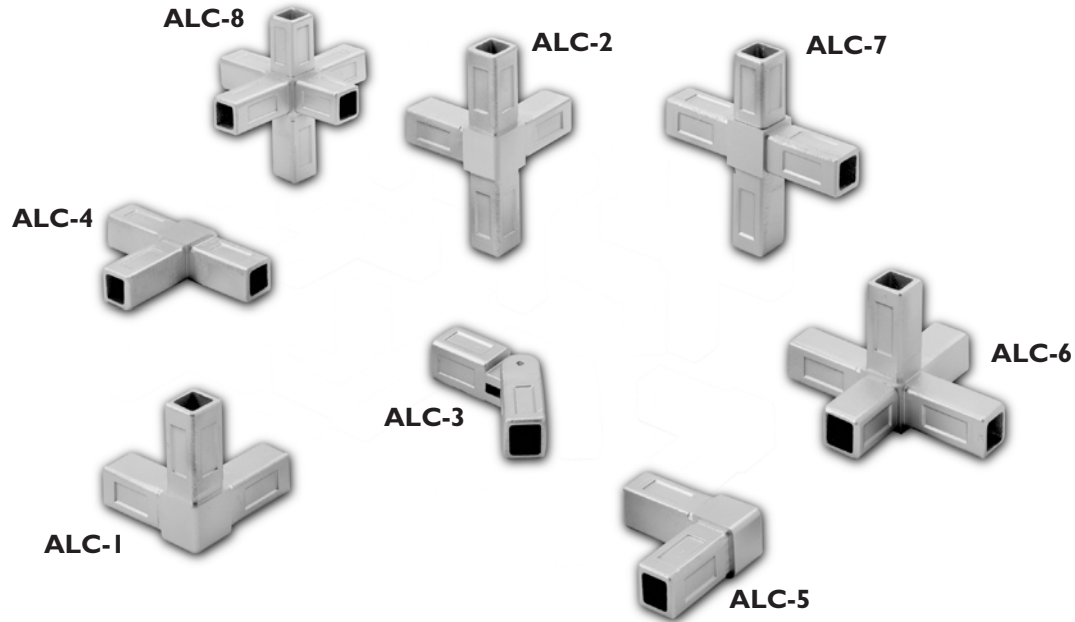

Cross Section

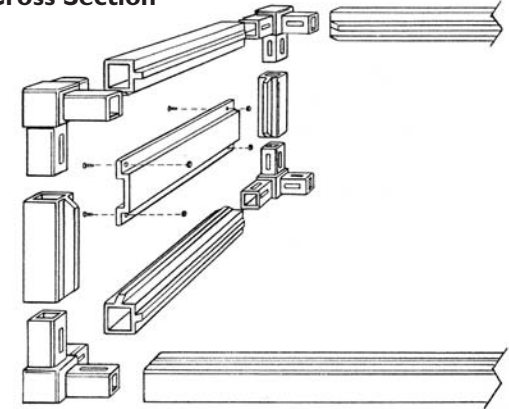

ALC-6, ALC-7 AND ALC-8 consist of two-piece bolted assemblies.
Note: Casting legs are undercut when necessary to provide optimal fit (structural integrity not affected).

Gussett, Pins and Clips



For Flush Mounting 1/8" (3.18mm) Flat Panels

ALE-1A Single flange for corner members 1/8" (3.18mm) flat panel.

ALE-2A Double flange for corner members 1/8" (3.18mm) flat panel.

ALE-2B Double flange, corner member for 1/8" (3.18mm) flat panel combination flush and recessed.

ALE-2D Double flange provides joining member for a series of panels.

ALE-3A Triple flange provides joining member for a series of panels.

ALE No flanges.

For Flush Mounting 5/8" (15.88mm) Formed Panels or Recessing 1/8" (3.18mm) Flat Panels

ALE-1 Single flange used as corner member flush 5/8" (15.88mm) or recessed 1/8" (3.18mm) panels.

ALE-2 Double flange used as corner member flush 5/8" (15.88mm) or recessed 1/8" (3.18mm) panels.

ALE-2C Double flange provides joining member for series mounting-flushing 5/8" (15.88mm).

ALE-3 Triple flange provides joining member for series mounting flush 5/8" (15.88mm) or recessed 1/8" (3.18mm) panels.

ALE-4 Quad flange provides center support joining member for internal series mounting flush 5/8" (15.88mm) or recessed 1/8" (3.18mm) panels.

Accessory Mounting Channels

ALS-A Horizontal support member used with ALE-1A, -2A, -2B and -3A series frame members for mounting ALM.

ALM Vertical adjustable recessed panel mounting channel.

ALS Horizontal support member used with ALE-1, -2 and -3 series frame members for mounting ALM.

Profiles

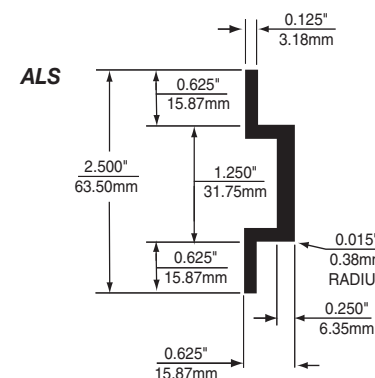
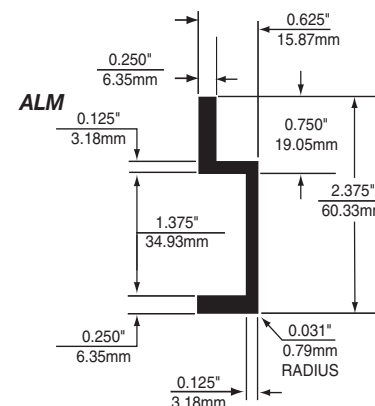
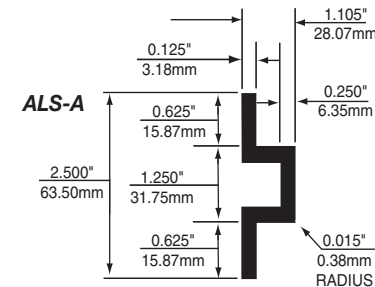
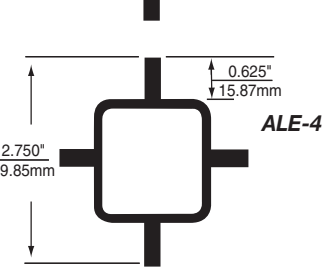
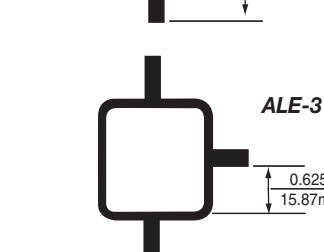
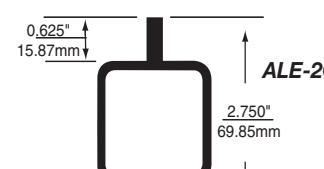
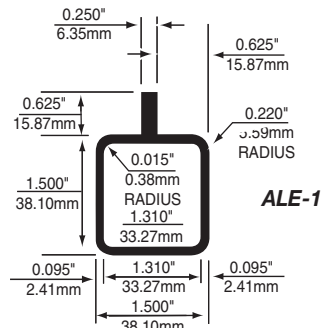
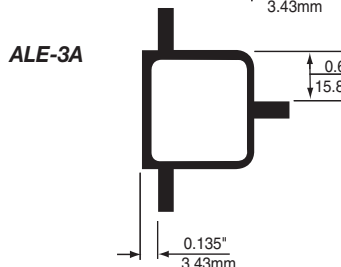
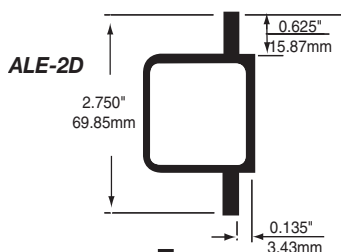
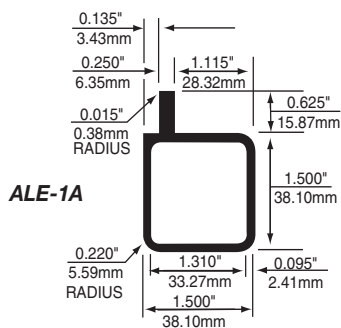

Note: Applicable to all extrusions: Tolerances to be in accordance with the aluminum association standards as applied to extruded shapes. Straightness, twist, flatness, and angularity to be in accordance with the aluminum association standards. Dimensions are for reference only.